

Assembly Instruction

Document No. 278124	Revision D				permobil
Production state SERIES					
Preform Date 2016-07-13	Preform By ROHO	Approved Date 2018-03-05	Approved By basel.nopri	Page 1	

Contents

REMOVAL AND REPLACEMENT — APE REAR ACTUATOR

Items needed for F3 & F5 Corpus..... 1	Items needed for F5 Corpus VS 26
Tools for F3 & F5 Corpus..... 1	Tools for F5 Corpus VS 26
Instruction F3 & F5 Corpus 2-25	Instruction F5 Corpus VS 27-48

Items needed for F3 & F5 Corpus

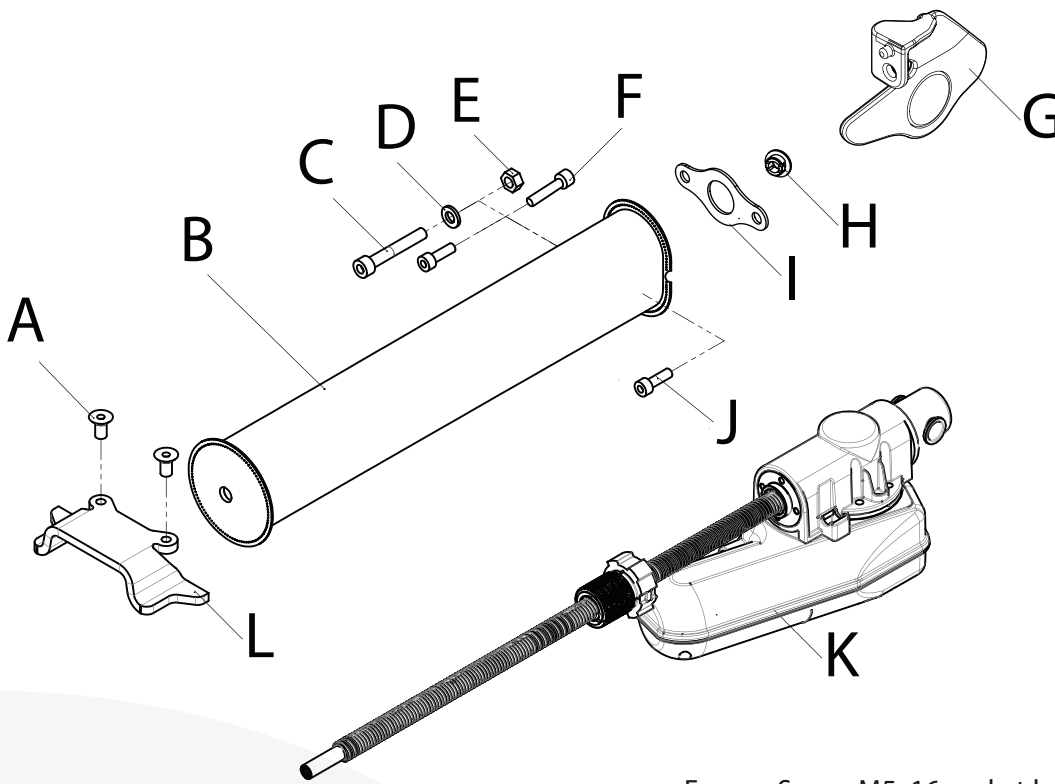

A	Screw M6x12 countersunk head	2 pc(s)	F	Screw M5x16 socket head	1 pc(s)
B	Textile tube	1 pc(s)	G	Magnet holder	1 pc(s)
C	Screw M6x40 socket head	1 pc(s)	H	Plastic bearing	1 pc(s)
D	Washer	1 pc(s)	I	Plate	1 pc(s)
E	Nut M6	1 pc(s)	J	Screw M5x12 socket head	2 pc(s)
			K	Actuator	1 pc(s)
			L	End stop	1 pc(s)

TOOLS NEEDED

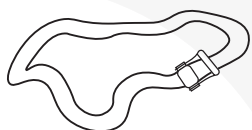

Strap with ratchet (approved for ≥200 kg/440 lbs).

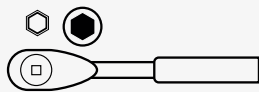

Torque wrench with socket 10 mm and hex key 3 mm, 4 mm, 5 mm.



Brush.



ICS switchbox if not installed on chair.

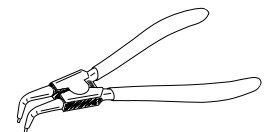

Circlip pliers.

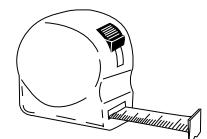

Measuring tape.

Document No. 278124	Revision D				permobil
Production state SERIES					
Preform Date 2016-07-13	Preform By ROHO	Approved Date 2018-03-05	Approved By basel.nopri	Page 2	

**CAUTION**

Installation by trained technician

The work should be performed or supervised by a technician who has received Permobil service training. Read all instructions carefully before proceeding with replacement of the actuator.

**CAUTION**

No user in the seating system

The user of the electrical wheelchair cannot be seated in the seating system during this repair.

**NOTICE**

Always change the textile tube

The textile tube should always be changed when the actuator is replaced.

- 1 Begin by fully elevating the seating and fully elevating the legrest.

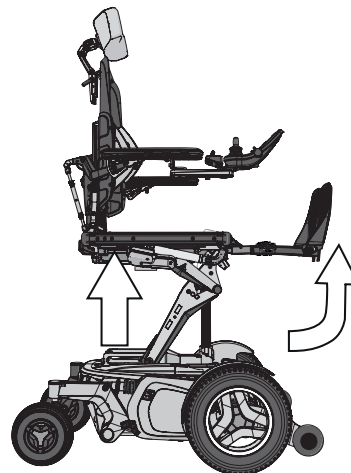

- 2 Remove the seat cushions by lifting it straight up. It is attached by means of velcro on the rear of the cushion. Remove the seat plates, which are held in place by four screws.

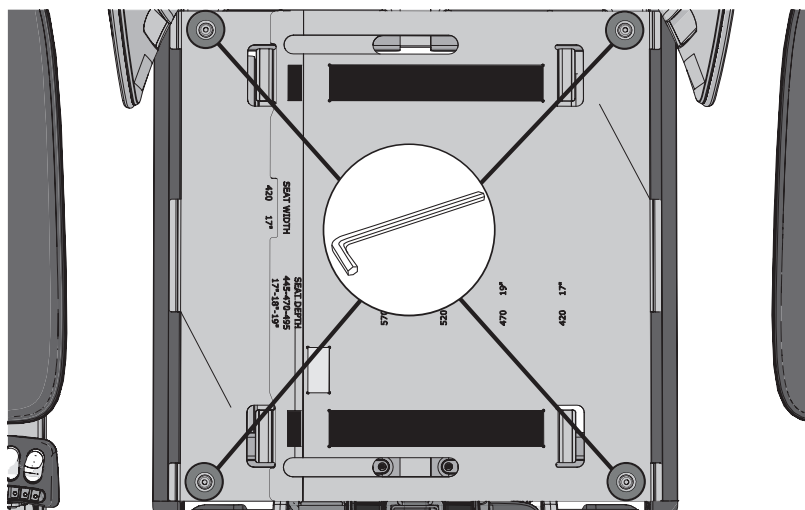

Document No. 278124	Revision D				permobil
Production state SERIES					
Preform Date 2016-07-13	Preform By ROHO	Approved Date 2018-03-05	Approved By basel.nopri	Page 3	

3 Remove the cable clips from the left and right side of the top plate. Save them for later installation.

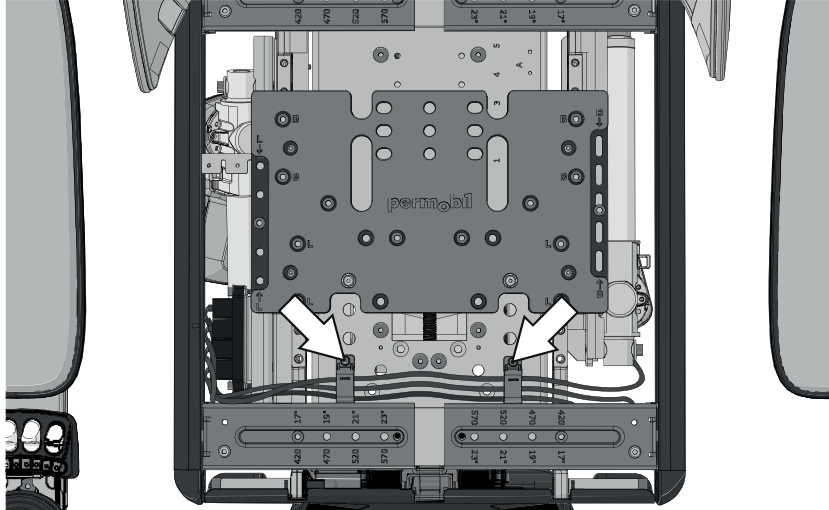

4 Note the location of the M6x12 bolts identified with smaller circles. The location of these bolts indicates the original seat depth. Remove these M6x12 bolts.

! The seating system is unbolted from the top plate in these steps. Carefully slide the seating system to and fro to gain access to the bolts required.

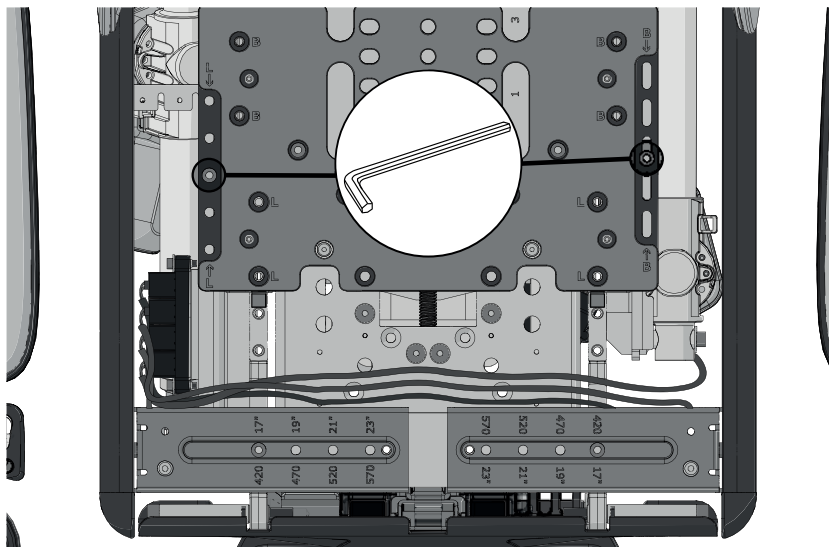

5 Remove the eight M6x25 bolts.

! The seating system is unbolted from the top plate in these steps. Carefully slide the seating system to and fro to gain access to the bolts required.

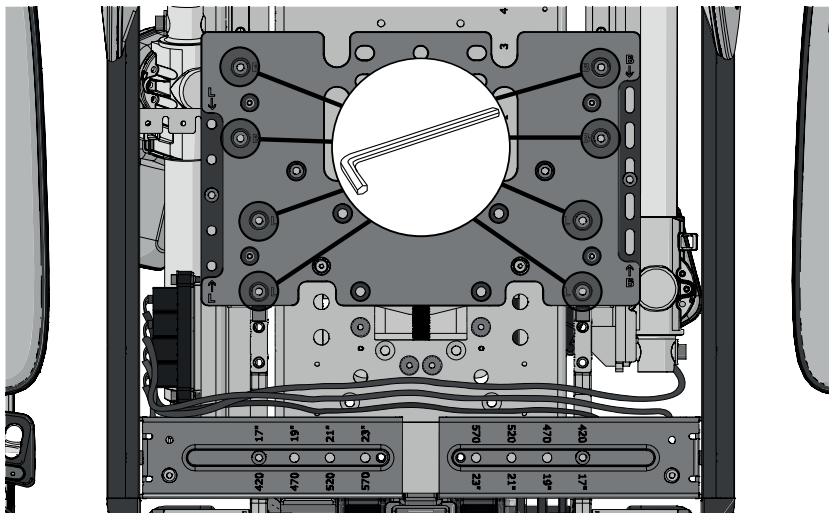

Document No. 278124	Revision D				permobil
Production state SERIES					
Preform Date 2016-07-13	Preform By ROHO	Approved Date 2018-03-05	Approved By basel.nopri	Page 4	

6 Note the center of gravity setting for re-assembly.

 This is very important.

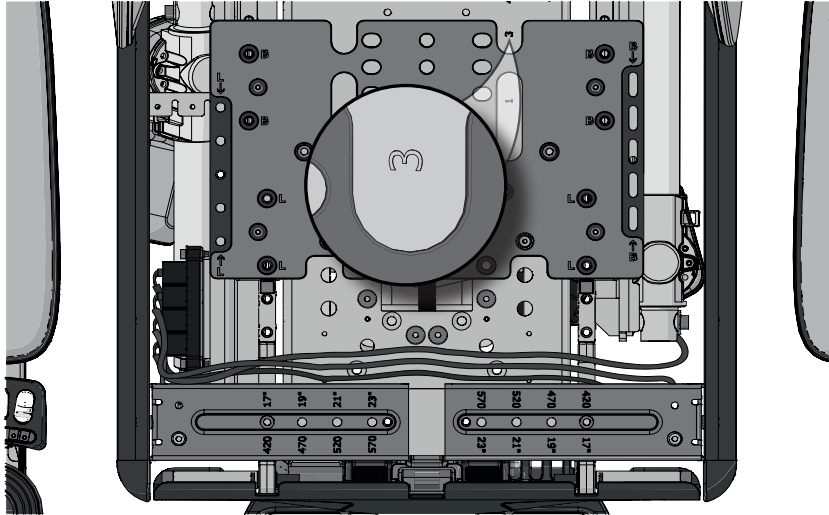

7 Remove the four M6x12 bolts. The plate and plastic cover are now disassembled.

 The seating system is unbolted from the top plate in these steps. Carefully slide the seating system to and fro to gain access to the bolts required.

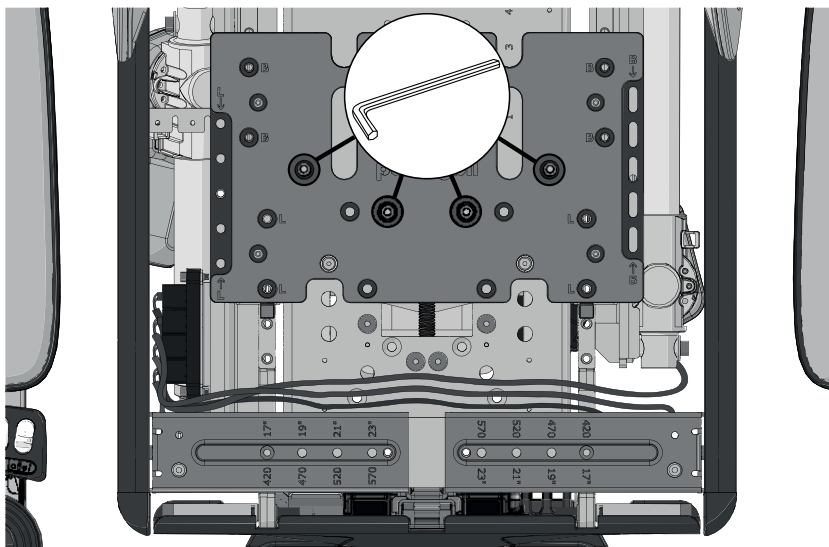

8 Push the plate and plastic cover backwards to expose the two bolts securing the end stop.

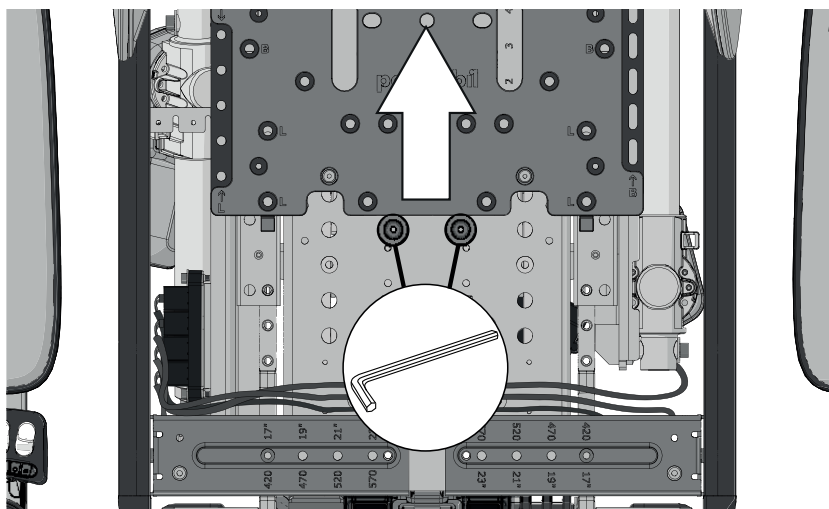

Document No. 278124	Revision D				permobil
Production state SERIES					
Preform Date 2016-07-13	Preform By ROHO	Approved Date 2018-03-05	Approved By basel.nopri	Page 5	

- 9** Remove the end stop and scrap. The end stop can look different depending on the revision. See **(A)** and **(B)**.

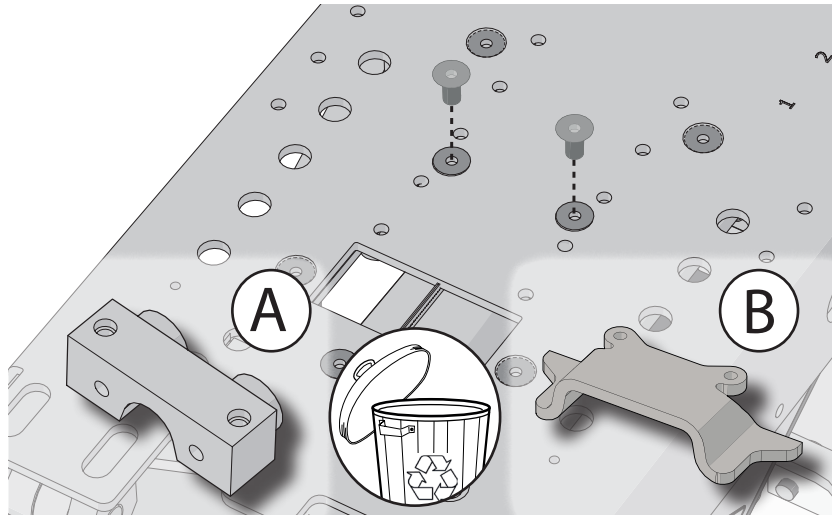

- 10** Return these 10 bolts to their original location and snug them tight. They will be removed again at a later stage.

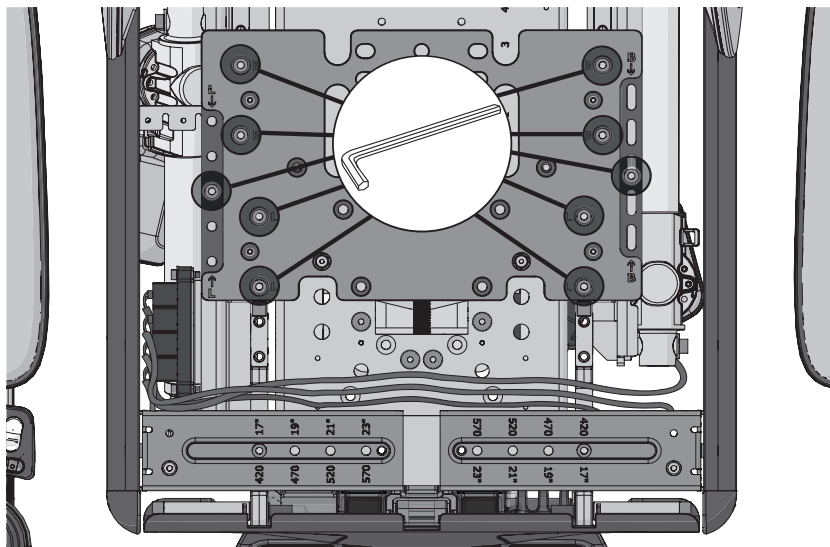

- 11** Remove the two M6x12 bolts securing the rear seat bar to the top plate.

! The seating system is unbolted from the top plate in these steps. Carefully slide the seating system to and fro to gain access to the bolts required.

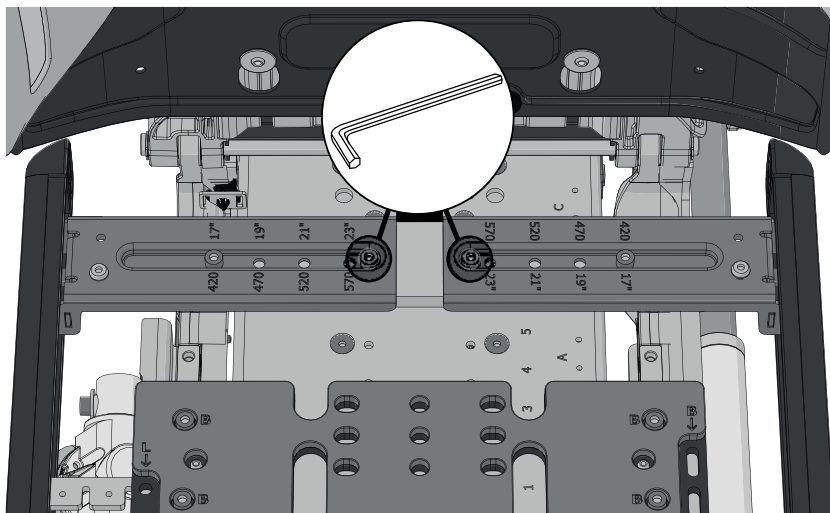

Document No. 278124	Revision D				permobil
Production state SERIES					
Preform Date 2016-07-13	Preform By ROHO	Approved Date 2018-03-05	Approved By basel.nopri	Page 6	

12 Carefully position the seating to gain access to the four bolts securing the actuator's holder. Remove the bolts securing the actuator's holder. Save the bolts.



The seating system is unbolted from the top plate in these steps. Carefully slide the seating system to and fro to gain access to the bolts required.

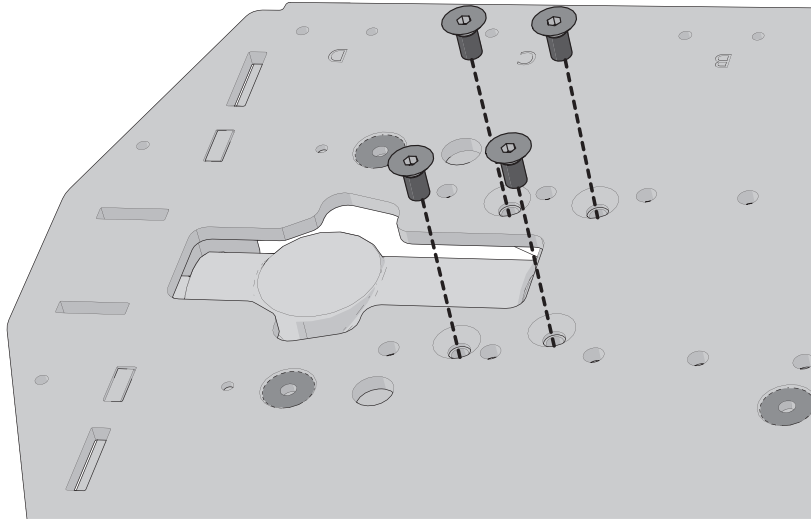

13 Remove and save the holder. Note the orientation for reassembly.

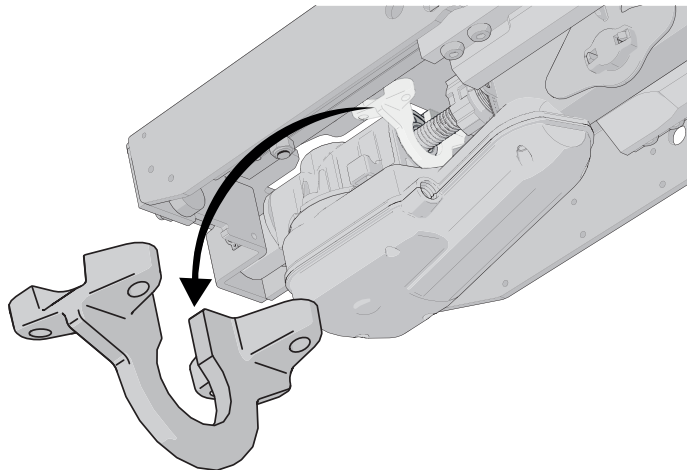

14 Return the two M6x12 bolts securing the rear seat bar to the top plate.



Failure to return these bolts will result in the seating system sliding off the top plate during the next steps.

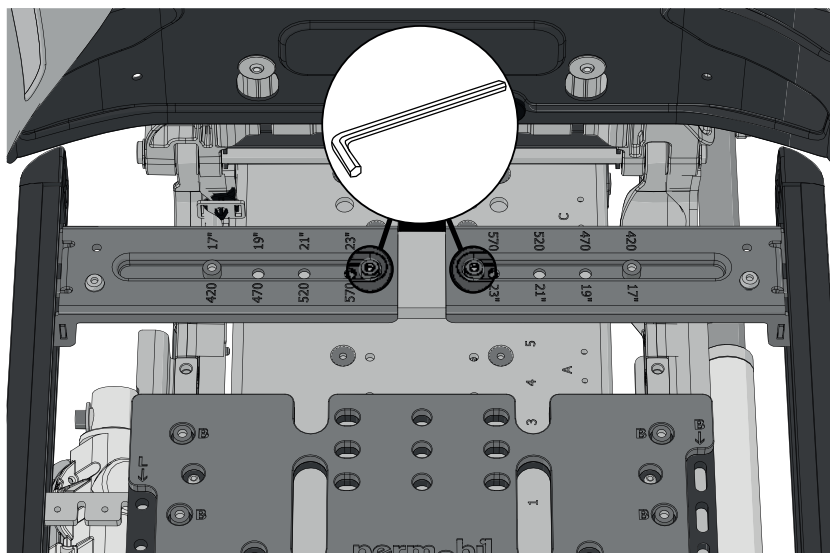

Document No. 278124	Revision D				permobil
Production state SERIES					
Preform Date 2016-07-13	Preform By ROHO	Approved Date 2018-03-05	Approved By basel.nopri	Page 7	

15 Place the plate in the "center of gravity", position 3, for easy access of the bolts in the coming steps.

Return the two M6x12 bolts.

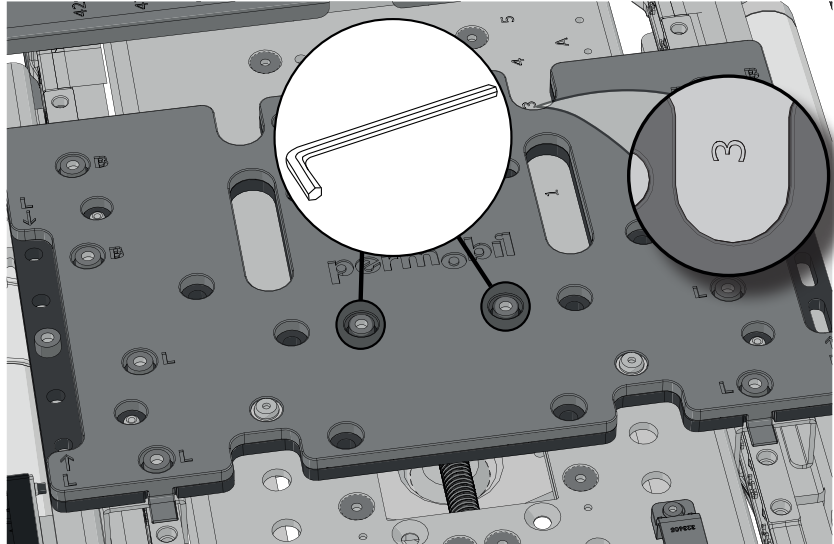

16 Check that the leg rest is fully elevated.

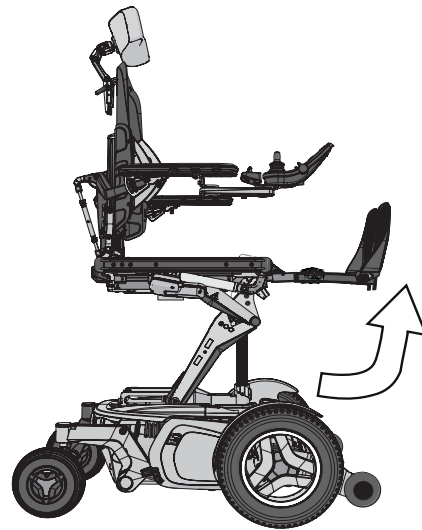

17 Enter seating into the Emergency operation mode.

Read instructions completely before starting!

1. Turn off the wheelchair.
2. Press and hold button 6 and button 8 on the ICS switchbox.
3. While holding these buttons, turn on the wheelchair with Power button on the joystick (or input device). All LED:s on the ICS switchbox will glow green, continue to hold buttons 6 and 8.
4. When all the ICS switchbox LED:s glow red, release buttons 6 and 8 (approximately 30 seconds). The switchbox LED:s will oscillate green to signify you are in Manual operation mode. If the switchbox LED:s do not oscillate green, begin again.



Document No. 278124	Revision D				permobil
Production state SERIES					
Preform Date 2016-07-13	Preform By ROHO	Approved Date 2018-03-05	Approved By basel.nopri	Page 8	

18 Press and hold button 5 to anterior tilt the seating system. The seating system will move very slowly. Monitor closely for binding or possible collision of seating.



19 The goal is to anterior tilt the seating to a position that allows easy access to the underside of the top plate. After reaching this position power down the chair.

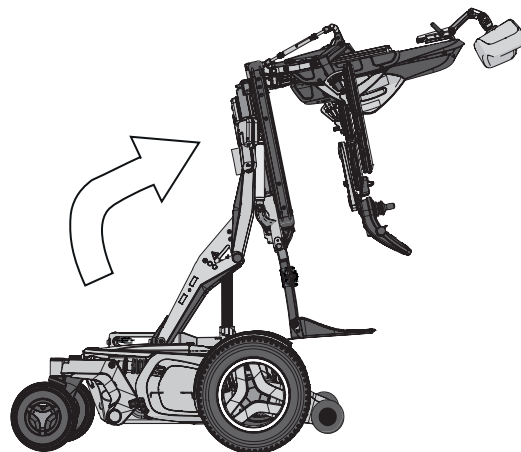

20 Remove the bracket holding the end of the actuator. Remove the plastic bearing from the bracket and scrap it and save the bracket for later. The bracket can look different depending on the revision. See **A** and **B**.

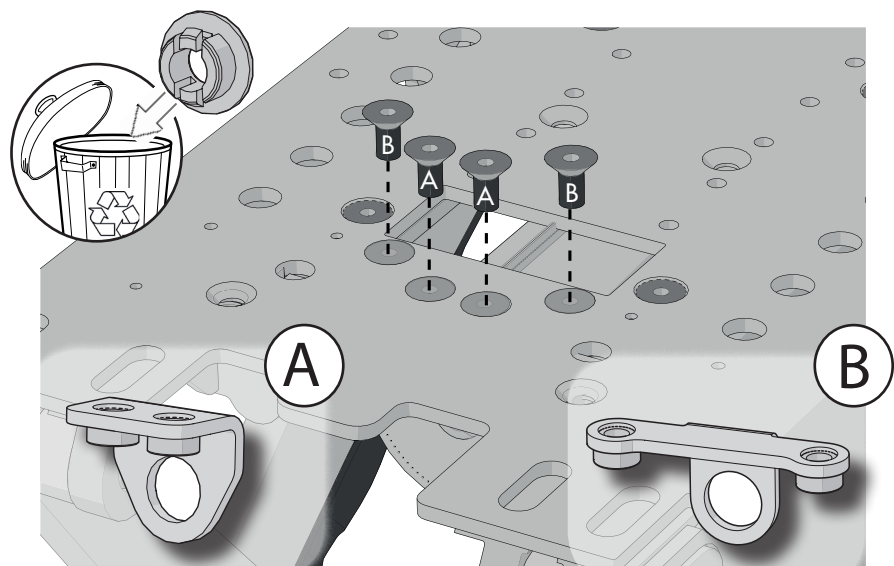

Assembly Instruction

Document No. 278124	Revision D				permobil
Production state SERIES					
Preform Date 2016-07-13	Preform By ROHO	Approved Date 2018-03-05	Approved By basel.nopri	Page 9	

21 Use a strap to secure the elevators position. Attach the strap to the leg rest and the shaft of the lower back of the AP elevator.

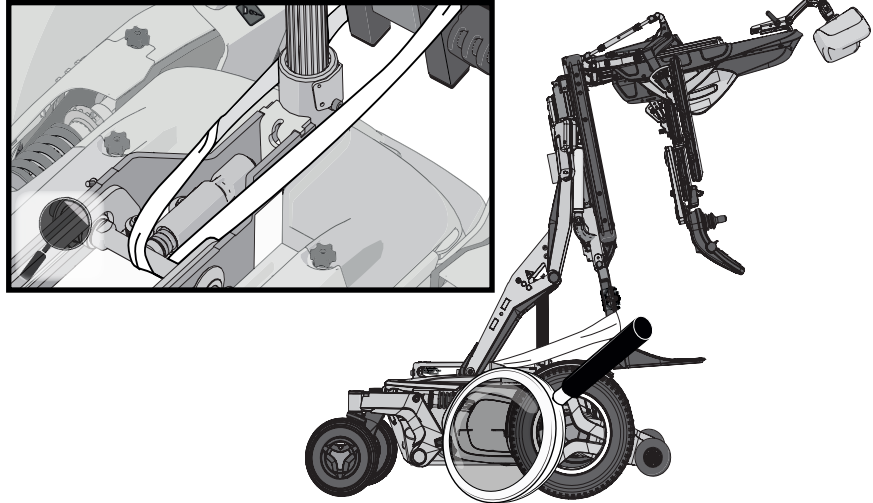

22 Remove the pinch guard from the top plate.

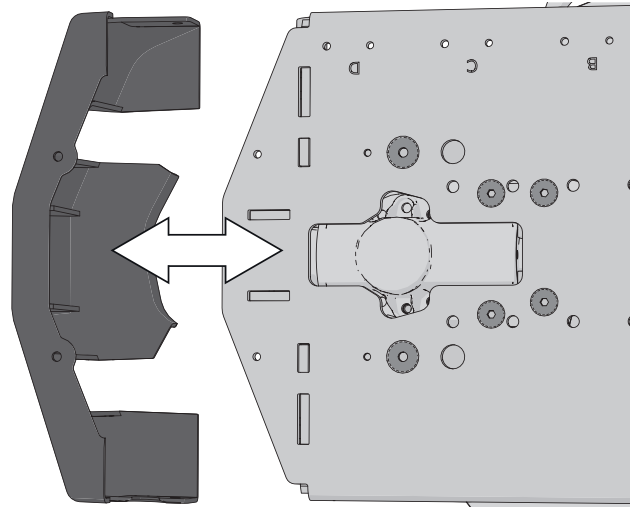

23 Remove the cable clip securing the wiring harness from the actuator. Disconnect the actuator lead from ICS system.

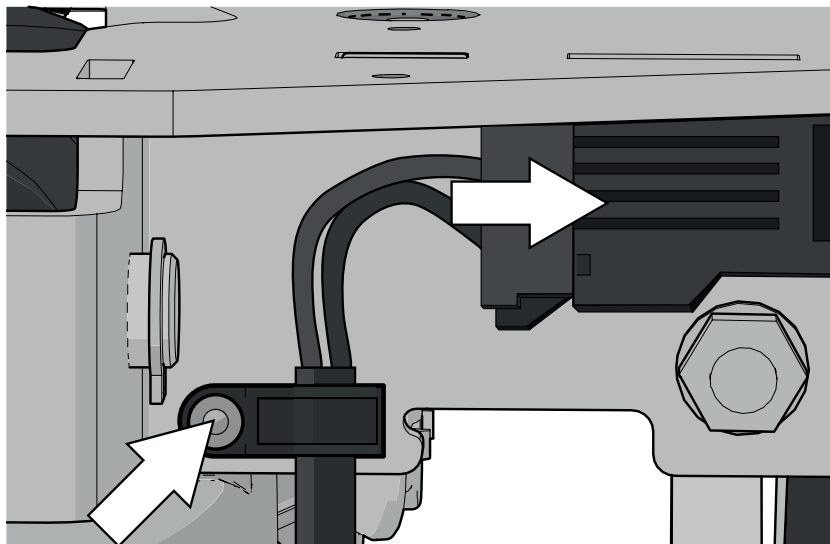

Document No. 278124	Revision D				permobil
Production state SERIES					
Preform Date 2016-07-13	Preform By ROHO	Approved Date 2018-03-05	Approved By basel.nopri	Page 10	

24 Remove the snap ring and pin securing the actuator to the top plate assembly.

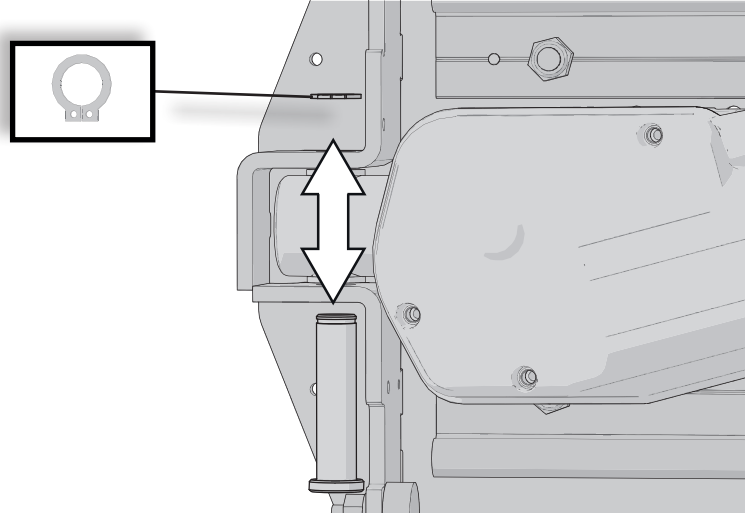

25 This action is not applicable for leg rest power extension and is only necessary if the seat width is 420 mm/17" with standard Corpus leg rest.

Loosen the bolts to widen the seat to at least 470 mm/19".

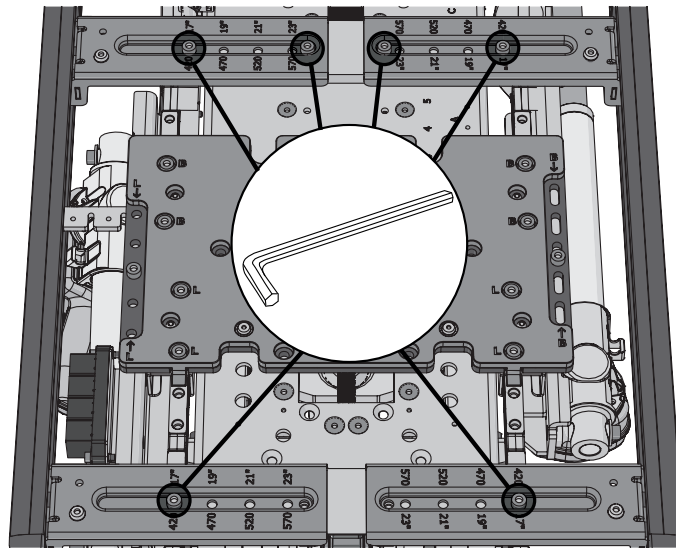

26 This action is not applicable for leg rest power extension.

Remove the two bolts securing the roller bracket. Remove the roller bracket (A), save the bolts and the roller bracket for later installation.

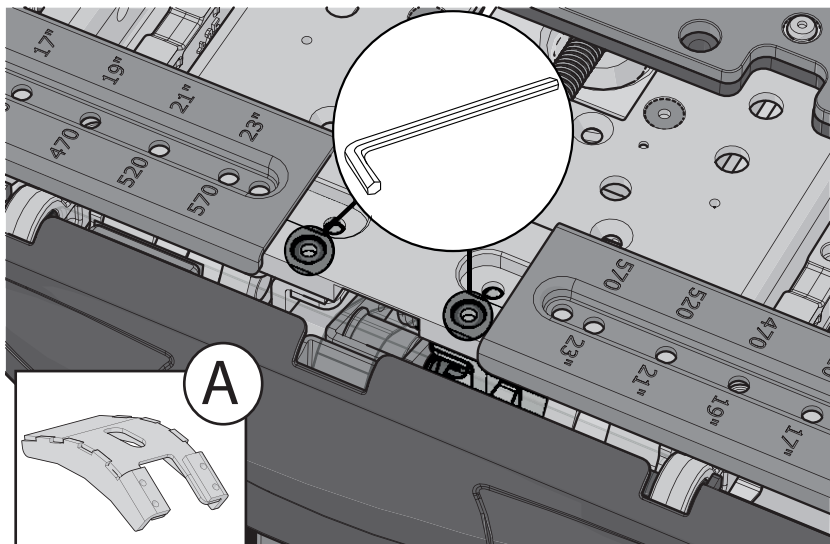

Document No. 278124	Revision D				permobil
Production state SERIES					
Preform Date 2016-07-13	Preform By ROHO	Approved Date 2018-03-05	Approved By basel.nopri	Page 11	

27 Depending on the revision of the carriage there are different actions.

Carriage (A): Remove the nut and scrap it. Remove the M6 and M5 screws and scrap them. Save the locking plate for later installation.



The textile cover should always be replaced when the actuator is replaced.

Carriage (B): Remove the three M5 screws and scrap them. Save the locking plate for later installation.



The textile cover should always be replaced when the actuator is replaced.

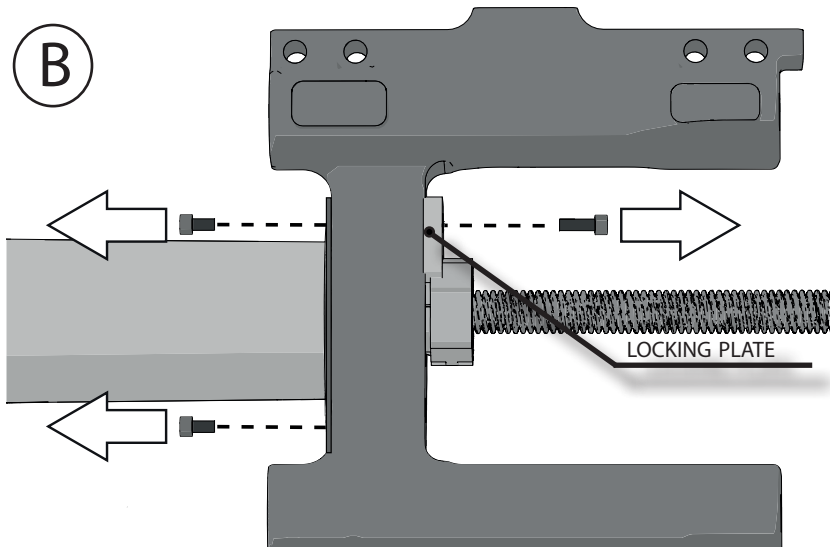
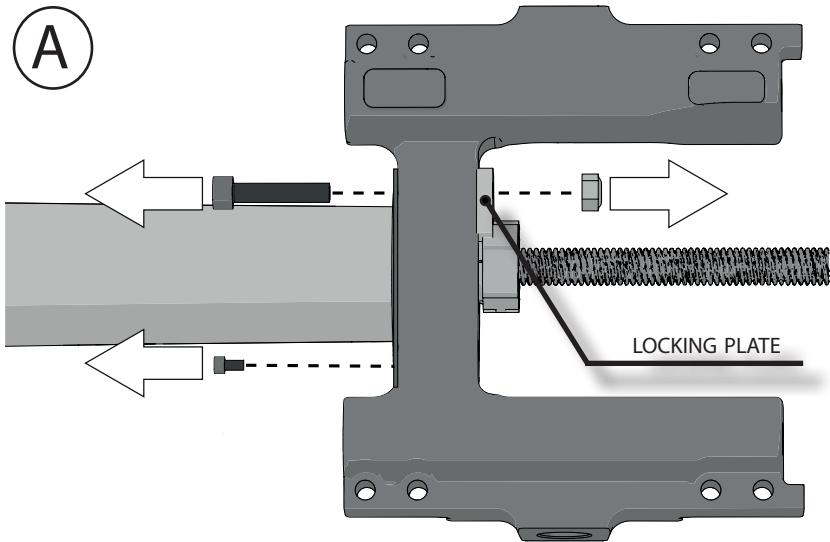

28 Unthread the polymer nut from the carriage.



Do not further move the position of the polymer nut after it is unthreaded from the carriage.

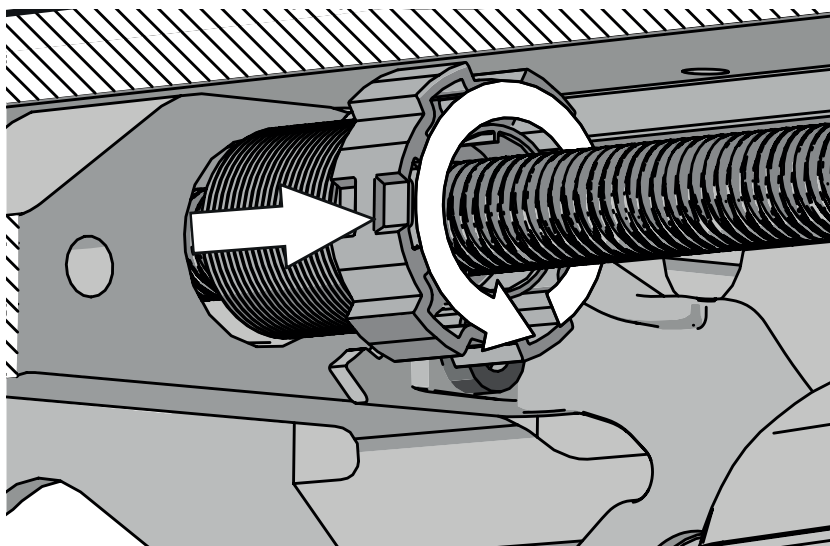

Document No. 278124	Revision D				permobil
Production state SERIES					
Preform Date 2016-07-13	Preform By ROHO	Approved Date 2018-03-05	Approved By basel.nopri	Page 12	

29 Remove the actuator.

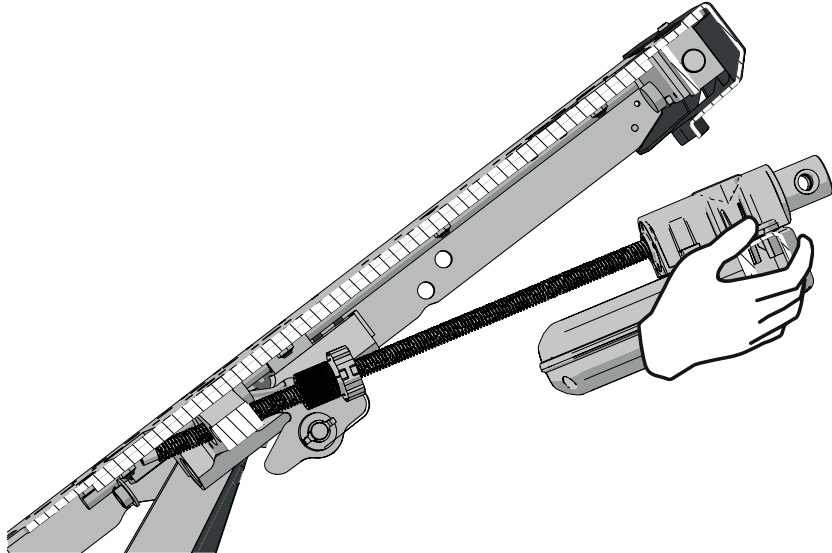

30 Remove the screw and the magnet holder and scrap them.

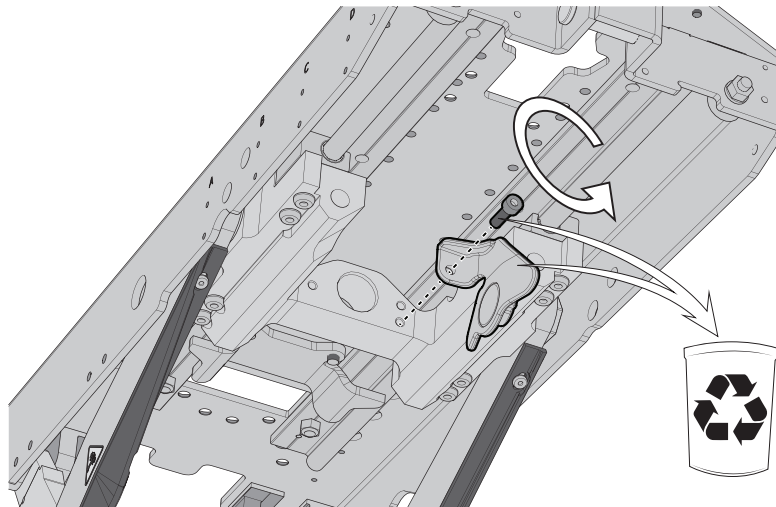

31 Mount the new magnet holder with the M5x16 screw

Tighten the screw with 2,9 Nm.

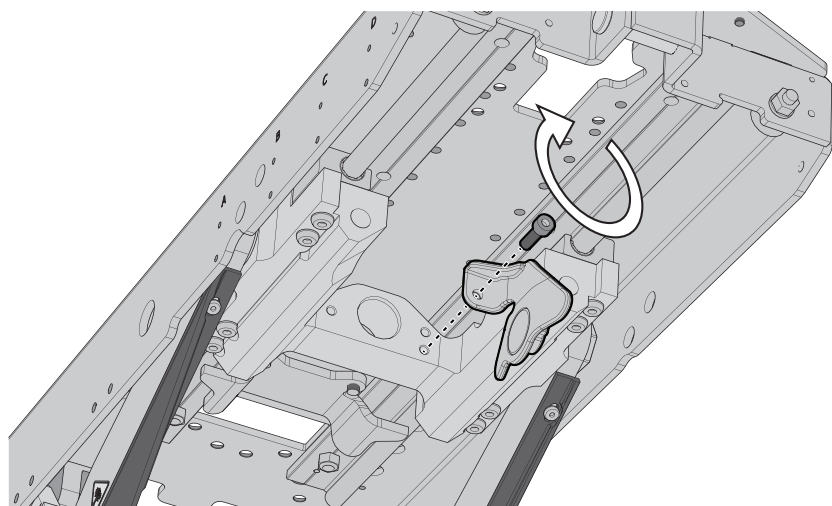

Assembly Instruction

Document No. 278124	Revision D				permobil
Production state SERIES					
Preform Date 2016-07-13	Preform By ROHO	Approved Date 2018-03-05	Approved By basel.nopri	Page 13	

32 Position, by eye, the polymer nut on the new actuator in the same position as the nut on the previously removed actuator.

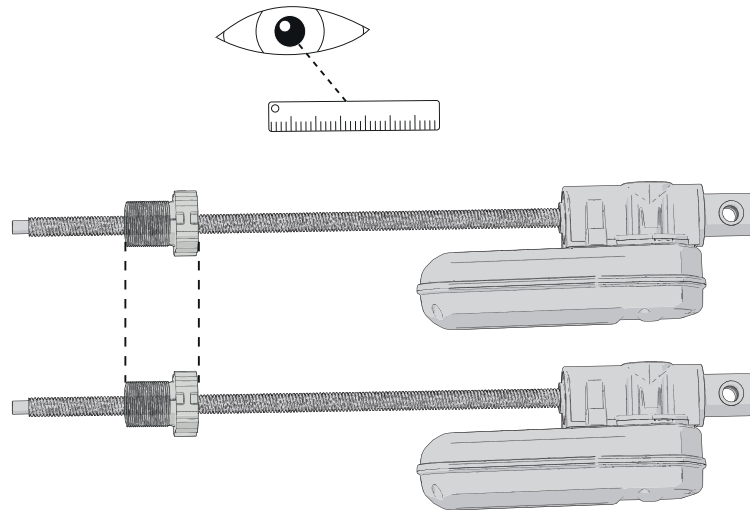

33 Insert the new actuator into the carriage. You might need to loosen the strap and tilt back the seat a little in order to fit the new actuator.

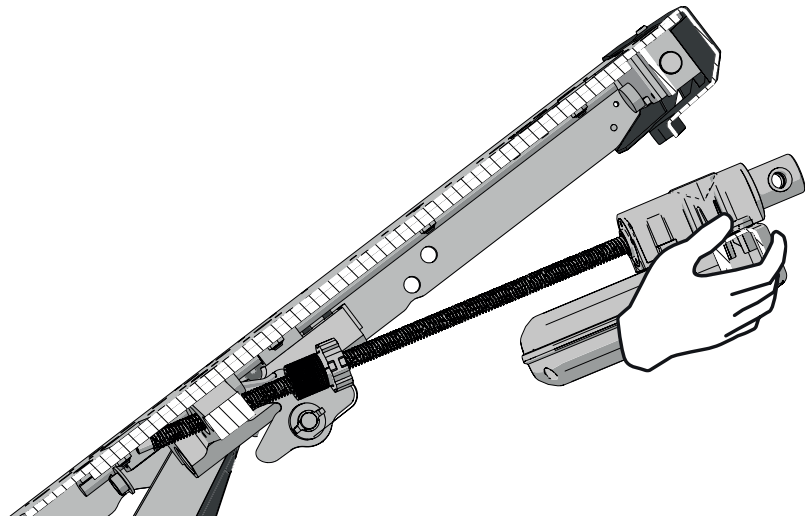

34 Mount the polymer nut in the carriage.



Do not use tools when mounting the polymer nut. Usage of tools can lead to critical damage on the polymer nut.

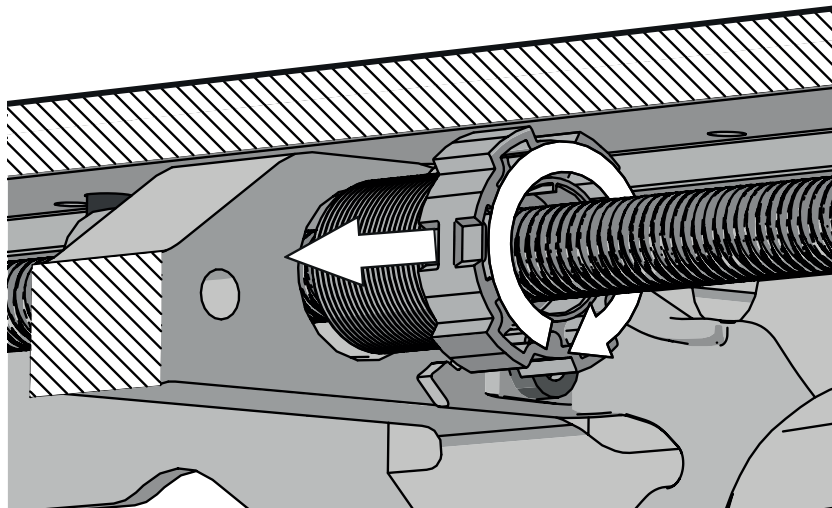

Assembly Instruction

Document No. 278124	Revision D				permobil
Production state SERIES					
Preform Date 2016-07-13	Preform By ROHO	Approved Date 2018-03-05	Approved By basel.nopri	Page 14	

35 There must be a gap of 0.5-1 mm between the polymer nut and the carriage.

 This is very important.

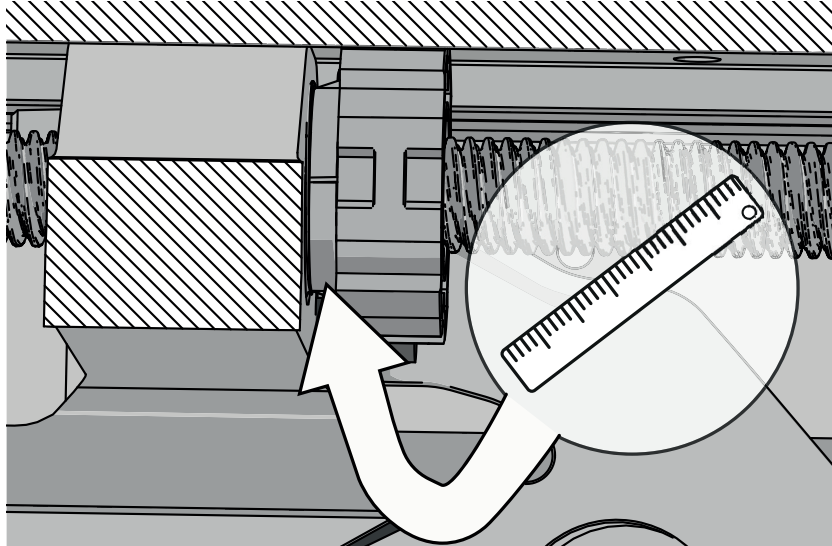

36 Mount the snap ring and pin securing the actuator to the top plate assembly.

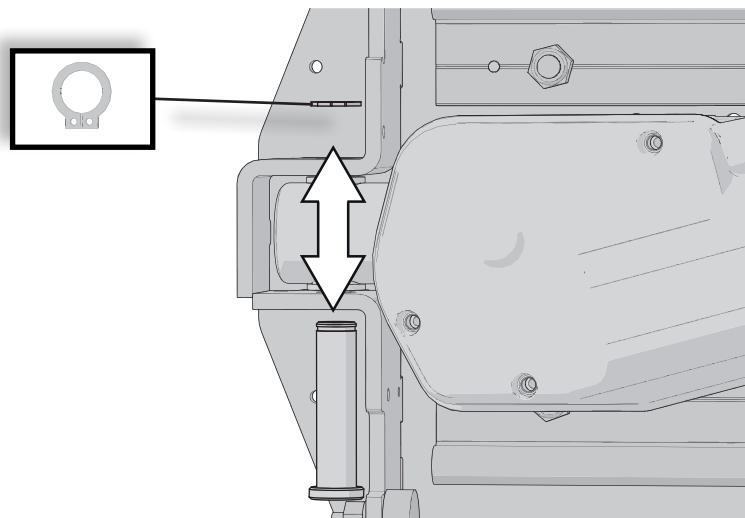

37 Detach the strap from the leg rest and the shaft of the lower back of the AP elevator.

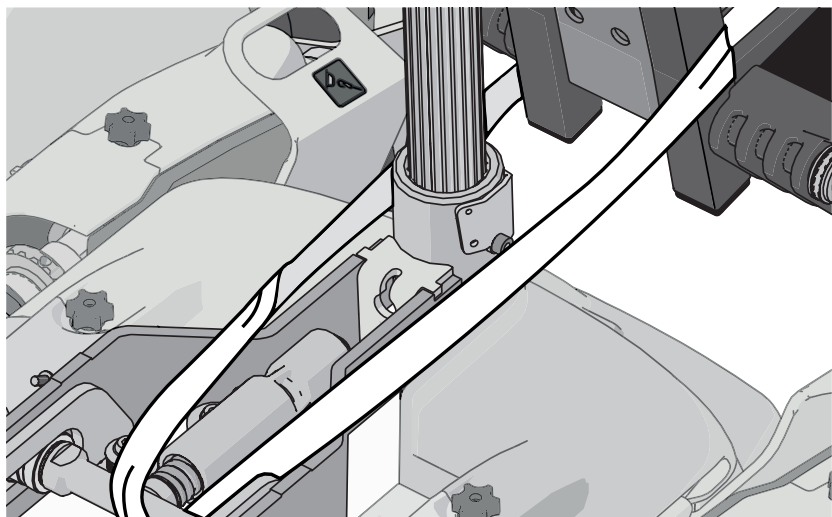

Assembly Instruction

Document No. 278124	Revision D				permobil
Production state SERIES					
Preform Date 2016-07-13	Preform By ROHO	Approved Date 2018-03-05	Approved By basel.nopri	Page 15	

38 This step is only necessary if the textile cover is in separate parts.

Drop the plastic bushing inside the textile cover. Work the bushing into the hole at the other end as shown.

I

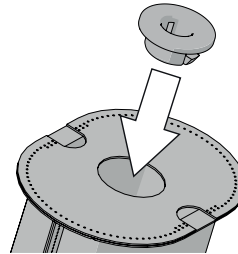

II

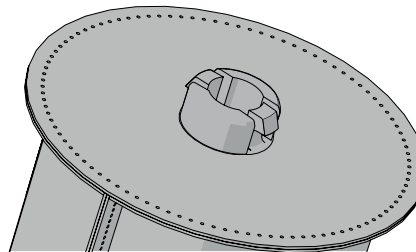

39 This step is only necessary if the textile cover is in separate parts.

Assemble the plate to the textile cover.

I

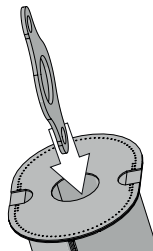

II

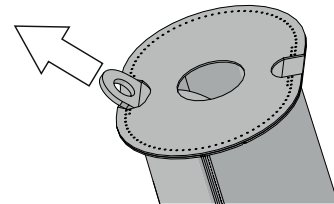

III

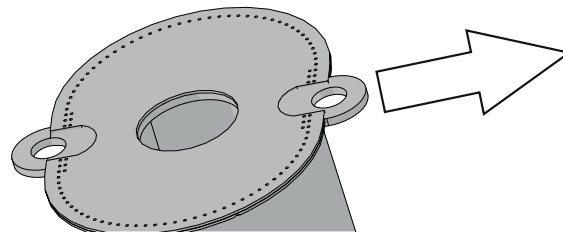

Document No. 278124	Revision D				permobil
Production state SERIES					
Preform Date 2016-07-13	Preform By ROHO	Approved Date 2018-03-05	Approved By basel.nopri	Page 16	

40 Mount the plastic bearing into the bracket. Apply grease (Molykote PG-75 or equal lubricant compatible with plastic and elastomer) on the inside of the bearing. The bracket can look different depending on the revision. See **A** and **B**.

! Make sure that the plastic bearing snaps in place properly into the bracket.

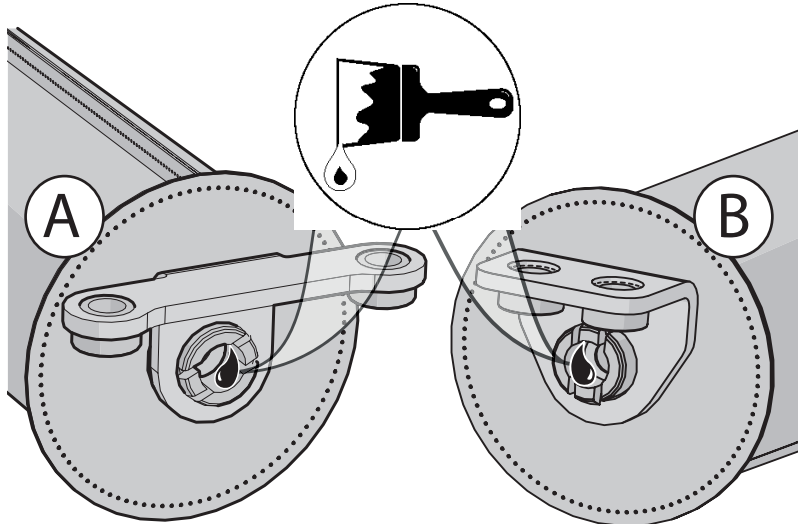

41 Slide the textile tube onto the actuator spindle. Make sure that the seam of the cover is facing the top plate's underside.

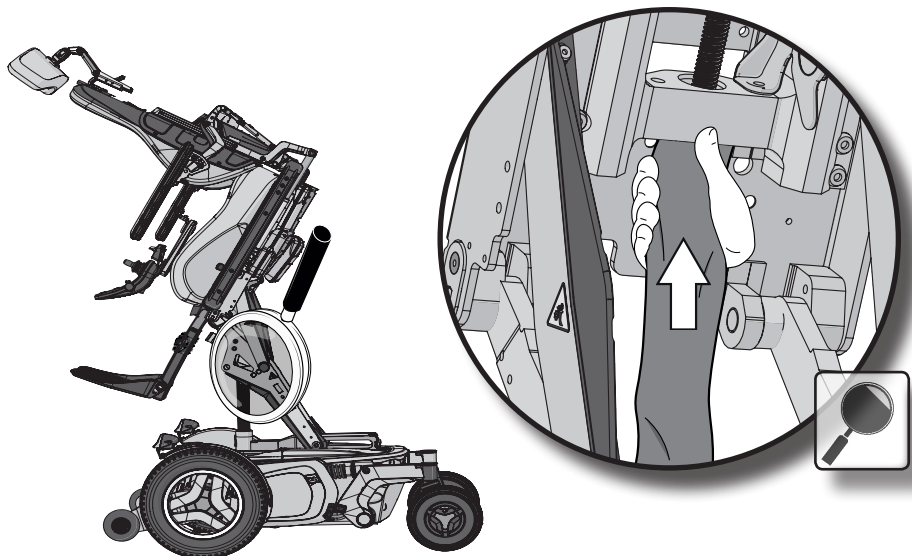

42 Mount one of the new M5x12 screws in the upper hole. Do not tighten the screw.

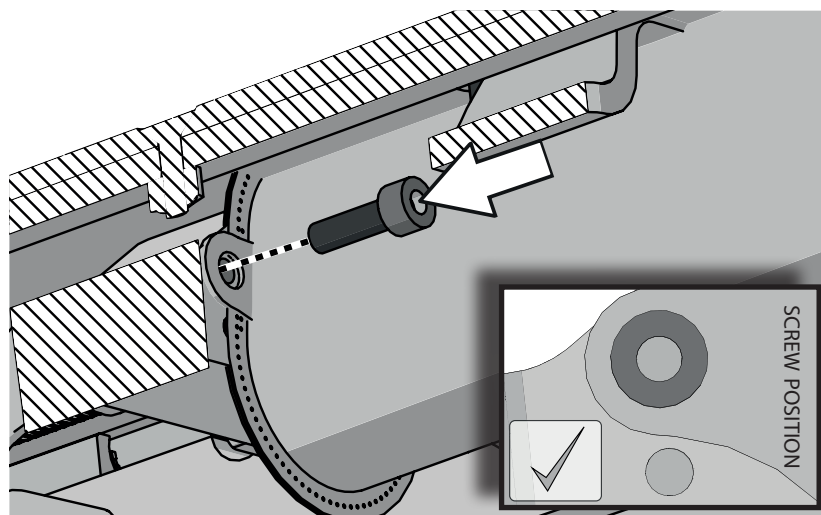

Document No. 278124	Revision D				permobil
Production state SERIES					
Preform Date 2016-07-13	Preform By ROHO	Approved Date 2018-03-05	Approved By basel.nopri	Page 17	

43 Depending on the revision of the carriage there are different actions.

Carriage (A): Mount the new M6x40 screw and washer. Tighten the screw with 9,8 Nm/ 7.2 lb.ft.
Mount the new nut, tighten it with 2,9 Nm/2.1 lb.ft.
Tighten the screw mounted in step 40.
Tighten with 5,7 Nm/4.2 lb.ft.

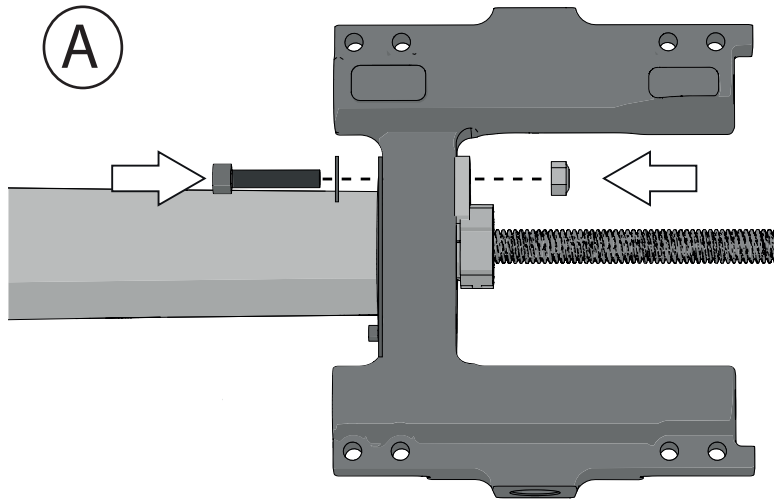

Carriage (B): Mount the M5x16 screw securing the locking plate. Mount the M5x12 screw securing the textile tube. Tighten all three screws, including the screw in step 40, with 5,7 Nm/4.2 lb.ft.

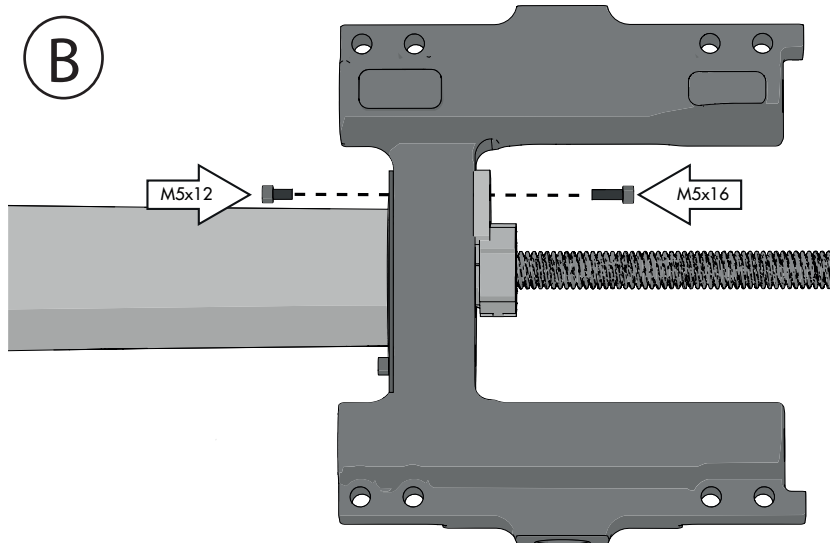

44 Connect the actuator lead to the ICS system and power the chair up thru the On/Off button on the input module. After the chair powers up all LED:s flashes red.

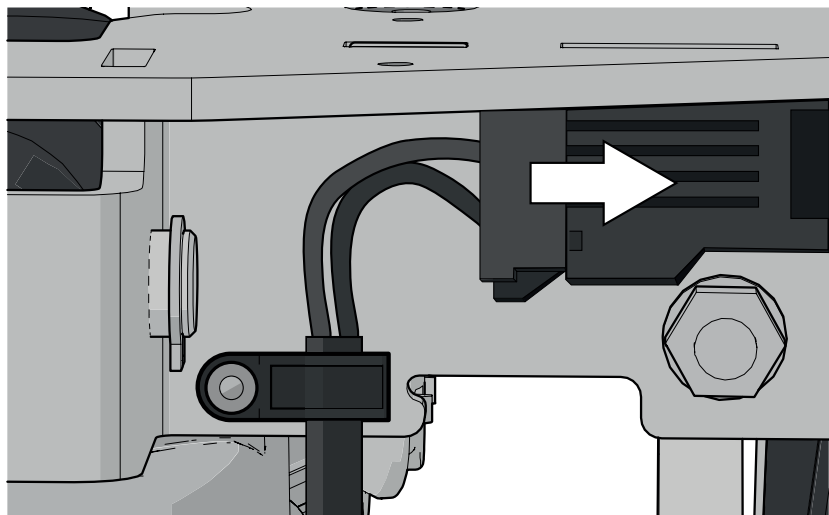

Assembly Instruction

Document No. 278124	Revision D				permobil
Production state SERIES					
Preform Date 2016-07-13	Preform By ROHO	Approved Date 2018-03-05	Approved By basel.nopri	Page 18	

45 Turn off the wheelchair and disconnect the actuator lead.

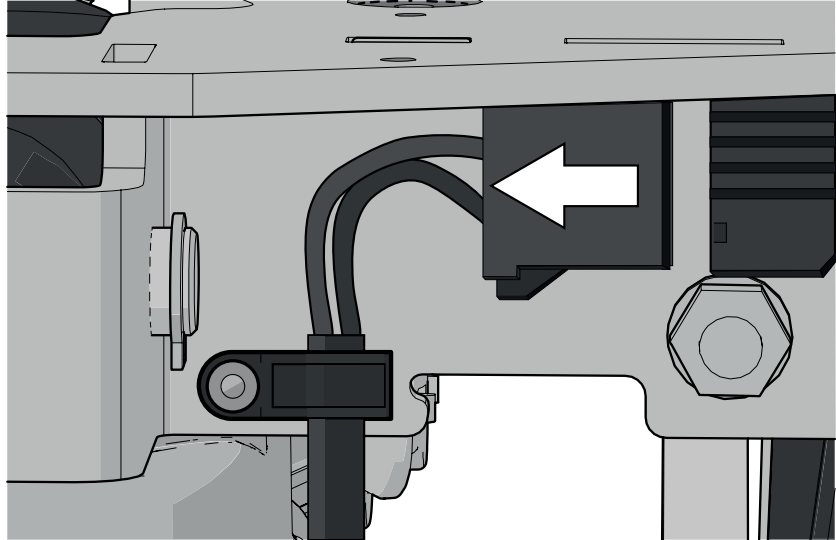

46 Power the chair up thru the On/Off button on the input module. After the chair powers up, connect the actuator lead to the ICS system. Install the cable clip securing the wiring harness from the actuator. Tighten the screw for the cable clip with 1,2 Nm/0.89 lb.ft.

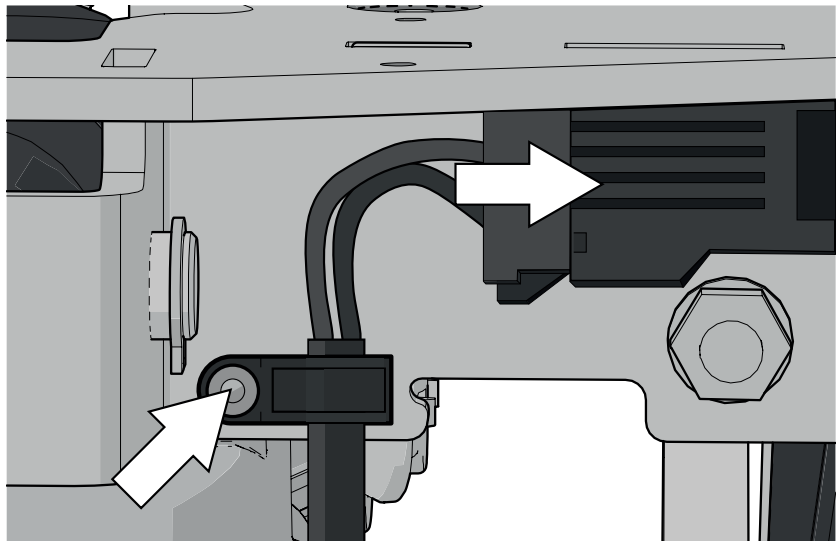

47 LED 1 will now flash red/yellow. The actuator is now in calibration mode.



Document No. 278124	Revision D				permobil
Production state SERIES					
Preform Date 2016-07-13	Preform By ROHO	Approved Date 2018-03-05	Approved By basel.nopri	Page 19	

48 Mount the bracket with two screws to the top plate. Tighten with 12,7 Nm/9.4 lb.ft. The bracket can look different depending on the revision. See **A** and **B**.

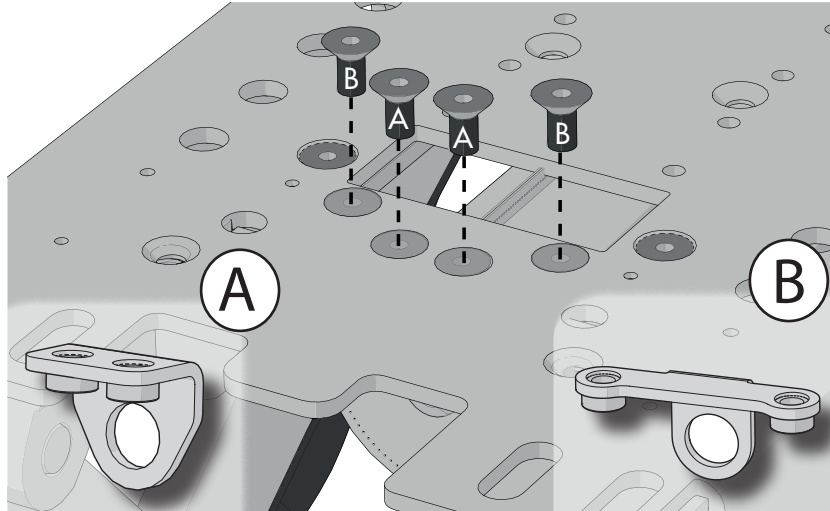

49 Push and hold button 1 to move the seating from its anterior tilt position to 0° horizontal position.



! Carefully monitor the textile cover as the seating moves. Make certain the cover does not entangle with the rotating spindle.



50 Push the plastic bearing onto the spindle. The bracket can look different depending on the revision. See **A** and **B**.

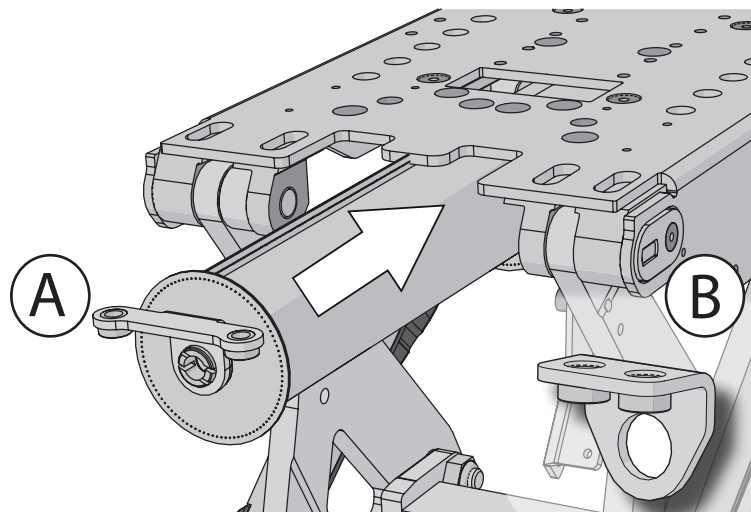

Assembly Instruction

Document No. 278124	Revision D				permobil
Production state SERIES					
Preform Date 2016-07-13	Preform By ROHO	Approved Date 2018-03-05	Approved By basel.nopri	Page 20	

51 Continue to push and hold button 1 until the actuator reaches the end stop and the LED:s flashes red.



52 When the LED:s flash red the system is requesting a restart. The system may require multiple restarts. Power the chair off and back on again. The switchbox will return to normal operation.



53 Return the seating to 0°/horizontal position and elevate the seating for access to the underside of the AP elevator's top plate.



Assembly Instruction

Document No. 278124	Revision D				permobil
Production state SERIES					
Preform Date 2016-07-13	Preform By ROHO	Approved Date 2018-03-05	Approved By basel.nopri	Page 21	

54 Mount back the pinch guard.

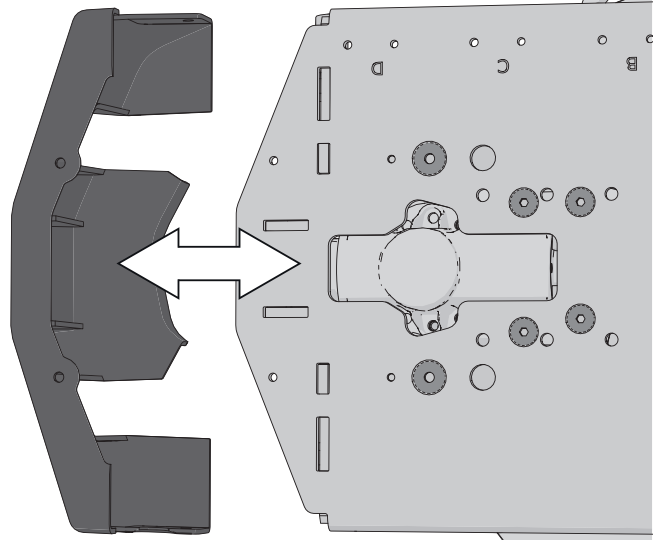

55 Make sure all of the marked bolts are removed so the plastic cover and plate can be moved back.

 The seating system is unbolted from the top plate in these steps. Carefully slide the seating system to and fro to gain access to the bolts required.

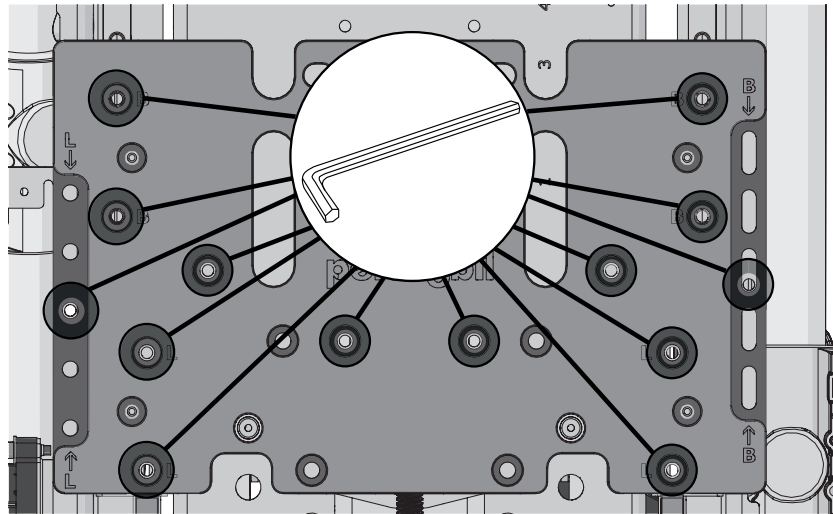

56 Work the bracket into position from the underside of the top plate. Install the new end stop with the new 2 pcs M6x12. Tighten with 12,7 Nm/9.4 lb.ft.

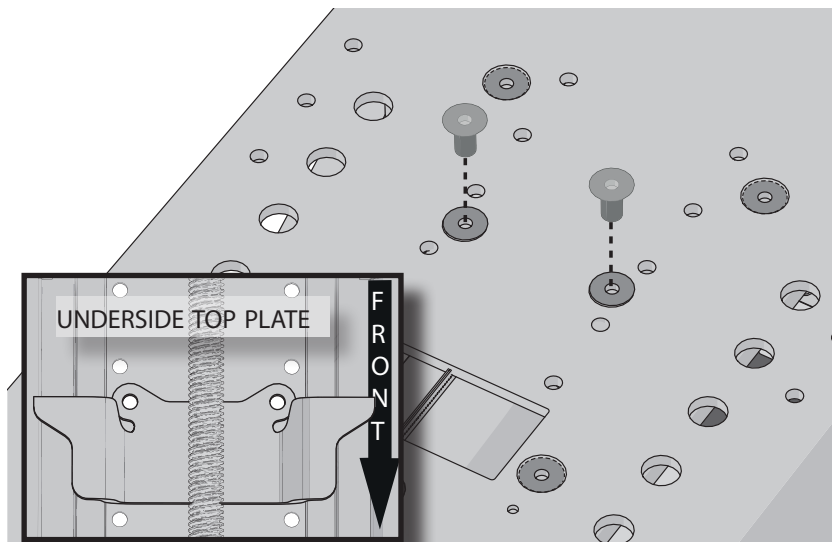

Document No. 278124	Revision D				permobil
Production state SERIES					
Preform Date 2016-07-13	Preform By ROHO	Approved Date 2018-03-05	Approved By basel.nopri	Page 22	

57 Remove the two M6x12 bolts securing the rear seat bar to the top plate. Move the seating system so you can access the screw holes in step 55.



The seating system is unbolted from the top plate in these steps. Carefully slide the seating system to and fro to gain access to the bolts required.

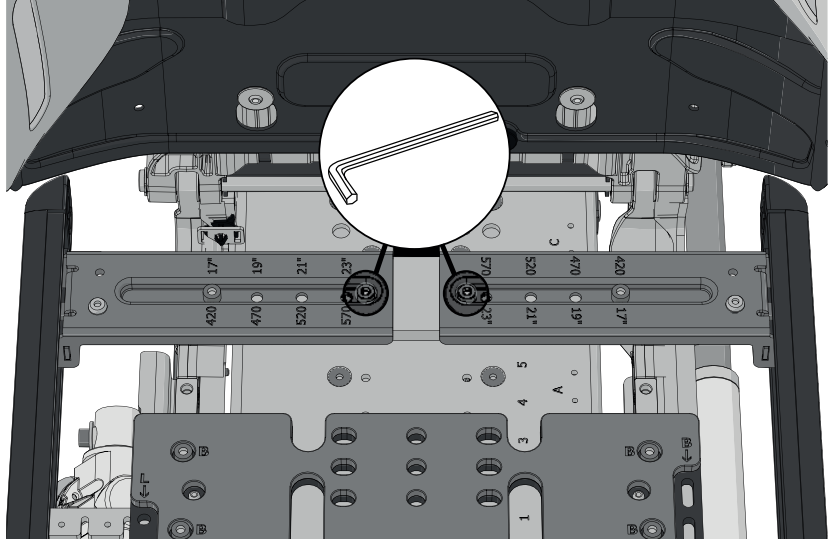

58 Return the actuator's holder.

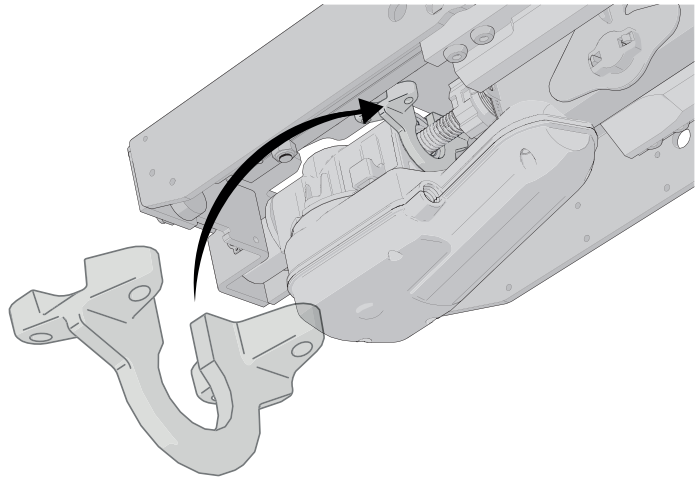

59 Reattach the holder with the four screws. Tighten with 7,4 Nm/5.5 lb.ft.

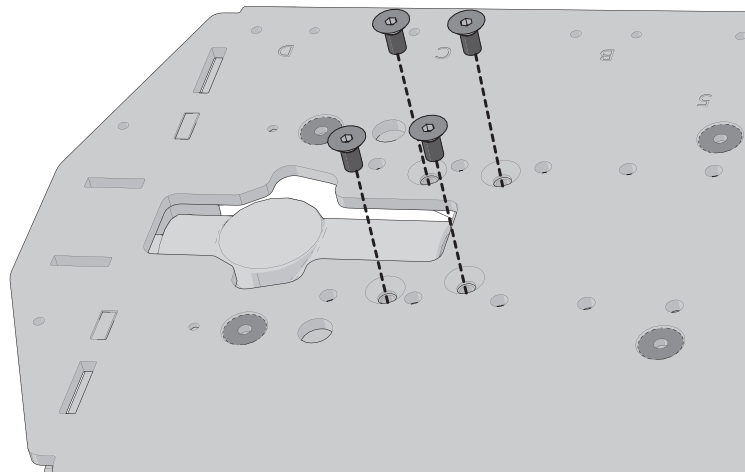

Document No. 278124	Revision D				permobil
Production state SERIES					
Preform Date 2016-07-13	Preform By ROHO	Approved Date 2018-03-05	Approved By basel.nopri	Page 23	

60 Adjust and reposition the seating to its original depth and center of gravity setting.

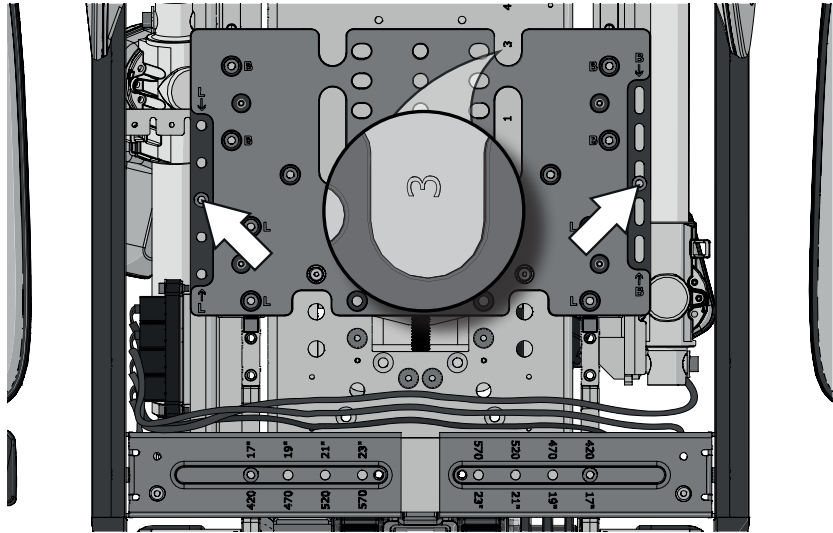

61 Reattach the bolts securing the plastic cover and plate. Tighten with 9,8 Nm/7,2 lb.ft.

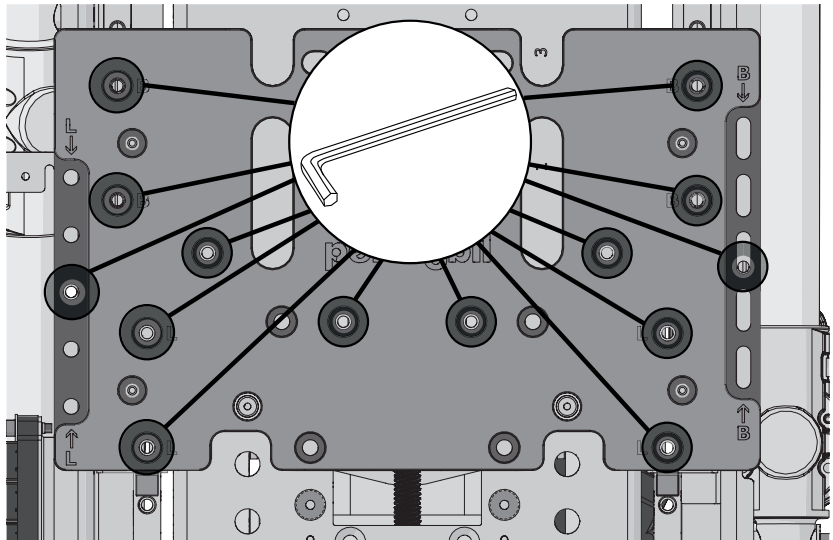

62 This action is not applicable for leg rest power extension. Reassemble the roller bracket (A). Reattach the two bolts securing the roller bracket. Tighten with 9,8 Nm/7,2 lb.ft.

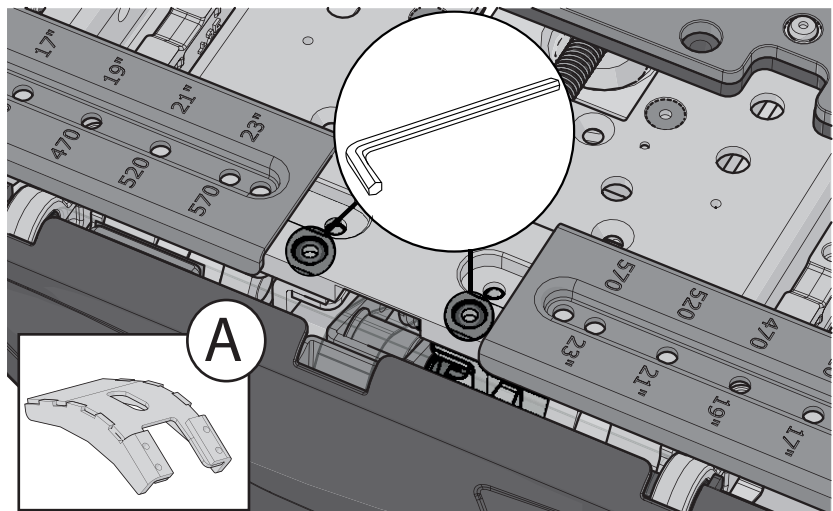

Assembly Instruction

Document No. 278124	Revision D				permobil
Production state SERIES					
Preform Date 2016-07-13	Preform By ROHO	Approved Date 2018-03-05	Approved By basel.nopri	Page 25	

66 Reattach the seat plates, which are held in place by four screws. Tighten with 9,8 Nm/7,2 lb.ft. Reattach the seat cushions. It is attached by means of velcro on the rear of the cushion.

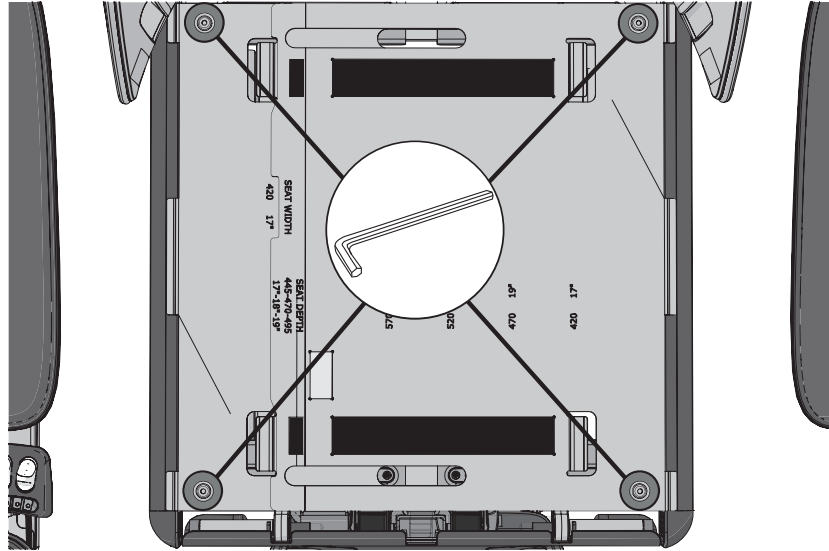

67 Carefully test the system for proper operation of the seat functions. Pay particular attention to the operation of tilt and the seat lift in both directions of travel. Make certain the textile cover cannot become entangled in the rotating spindle.

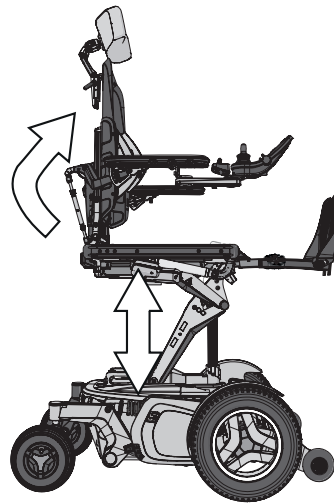

Document No. 278124	Revision D				permobil
Production state SERIES					
Preform Date 2016-07-13	Preform By ROHO	Approved Date 2018-03-05	Approved By basel.nopri	Page 26	

Items needed for F5 Corpus VS

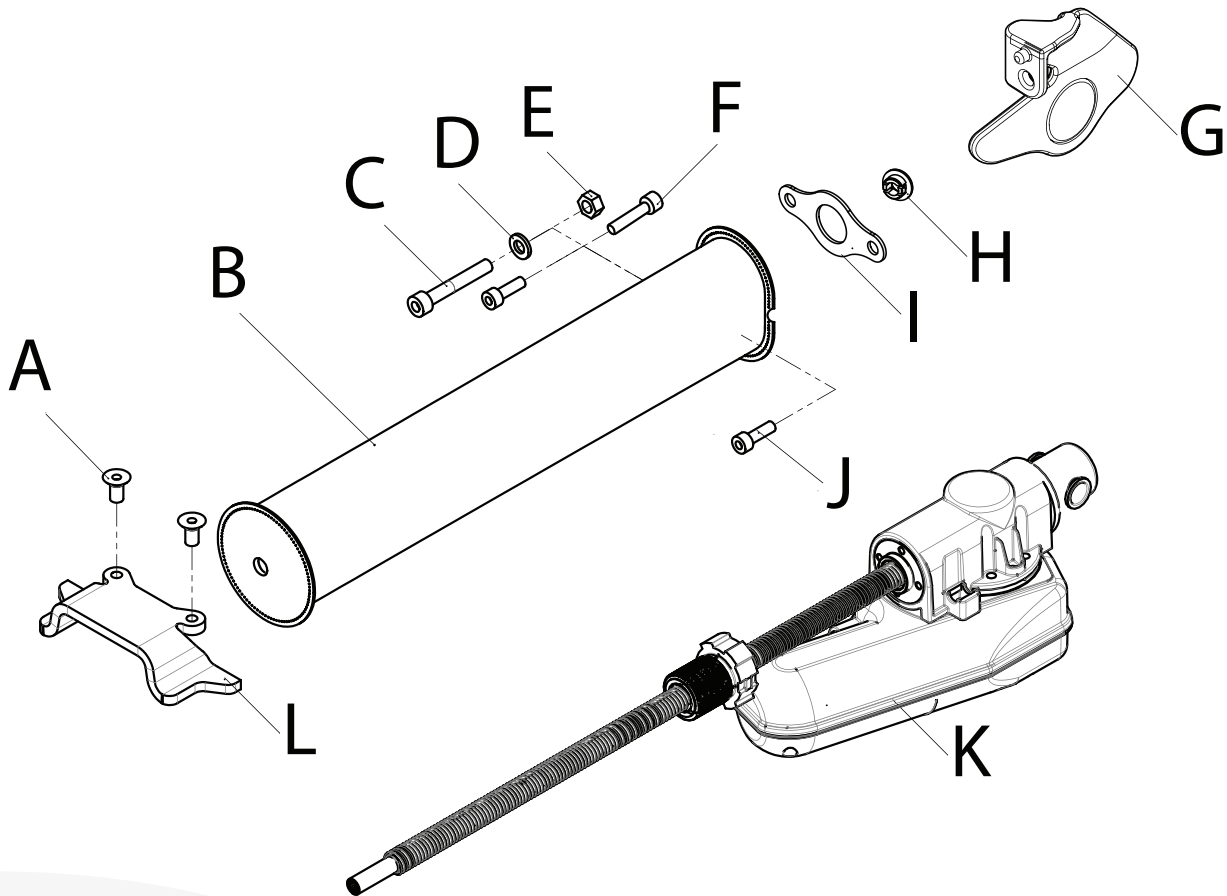

A	Screw M6x12 countersunk head	2 pc(s)	F	Screw M5x16 socket head	1 pc(s)
B	Textile tube	1 pc(s)	G	Magnet holder	1 pc(s)
C	Screw M6x40 socket head	1 pc(s)	H	Plastic bearing	1 pc(s)
D	Washer	1 pc(s)	I	Plate	1 pc(s)
E	Nut M6	1 pc(s)	J	Screw M5x12 socket head	2 pc(s)
			K	Actuator	1 pc(s)
			L	End stop	1 pc(s)

TOOLS NEEDED



Strap with ratchet (approved for ≥ 200 kg/440 lbs).

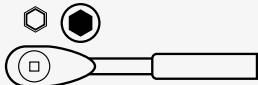

Torque wrench with socket 10 mm and hex key 3 mm, 4 mm, 5 mm.



Brush.



ICS switchbox if not installed on chair.

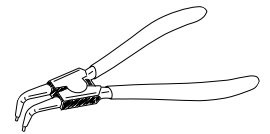

Circlip pliers.

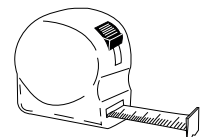

Measuring tape.

Document No. 278124	Revision D				permobil
Production state SERIES					
Preform Date 2016-07-13	Preform By ROHO	Approved Date 2018-03-05	Approved By basel.nopri	Page 27	

**CAUTION**

Installation by trained technician

The work should be performed or supervised by a technician who has received Permobil service training. Read all instructions carefully before proceeding with replacement of the actuator.

**CAUTION**

No user in the seating system

The user of the electrical wheelchair cannot be seated in these seating system during this repair.

**NOTICE**

Always change the textile tube

The textile tube should always be changed when the actuator is replaced.

- 1 Begin by fully elevating the seating and fully elevating the legrest.

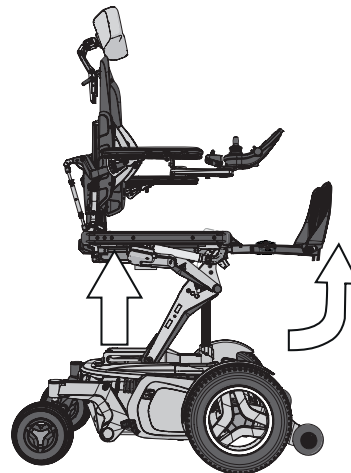

- 2 Remove the seat cushions by lifting it straight up. It is attached by means of velcro on the rear of the cushion. Remove the seat plates, which are held in place by four screws.

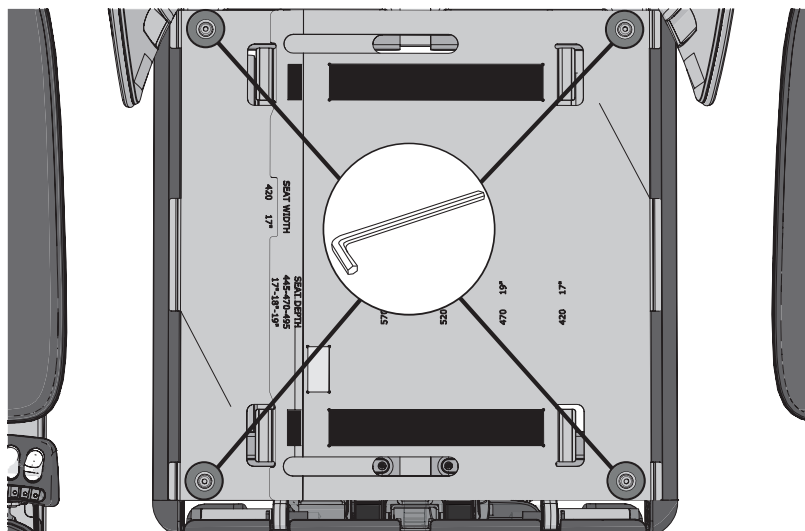

Document No. 278124	Revision D				permobil
Production state SERIES					
Preform Date 2016-07-13	Preform By ROHO	Approved Date 2018-03-05	Approved By basel.nopri	Page 28	

3 Remove the cable clips from the left and right side of the top plate. Save them for later installation.

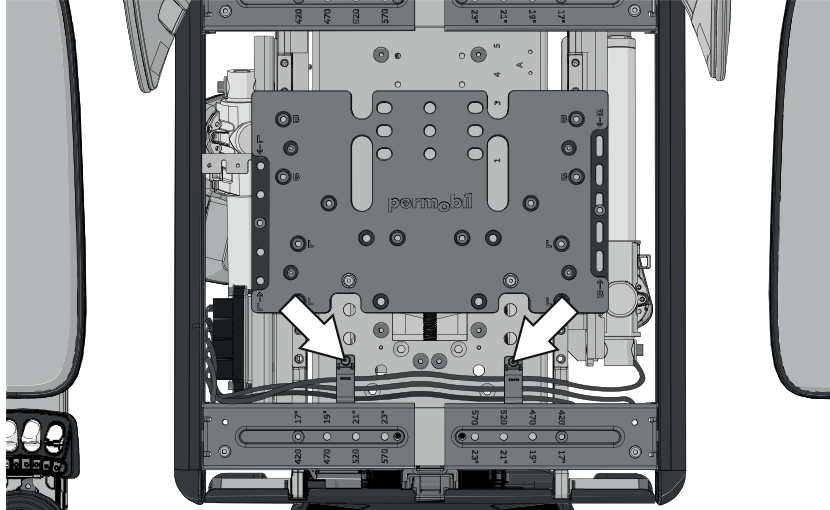

4 Note the location of the M6x12 bolts identified with smaller circles. The location of these bolts indicates the original seat depth. Remove these M6x12 bolts.

! The seating system is unbolted from the top plate in these steps. Carefully slide the seating system to and fro to gain access to the bolts required.

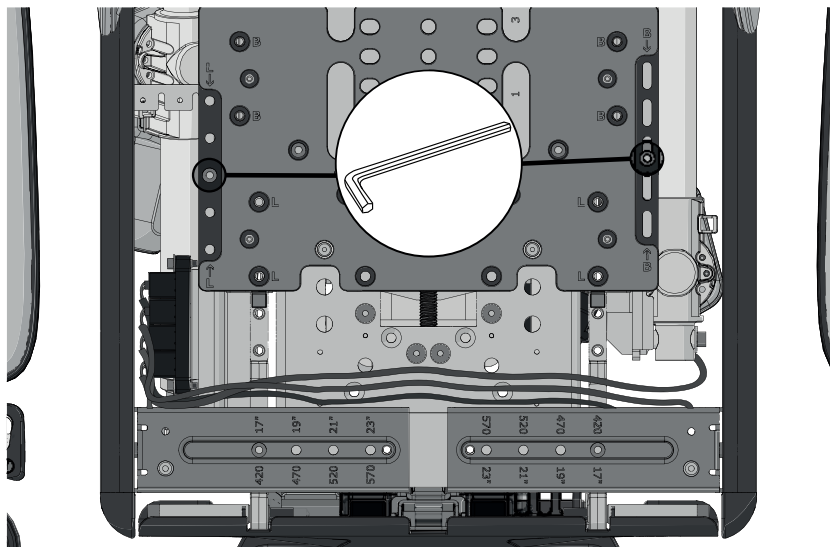

5 Remove the eight M6x25 bolts.

! The seating system is unbolted from the top plate in these steps. Carefully slide the seating system to and fro to gain access to the bolts required.

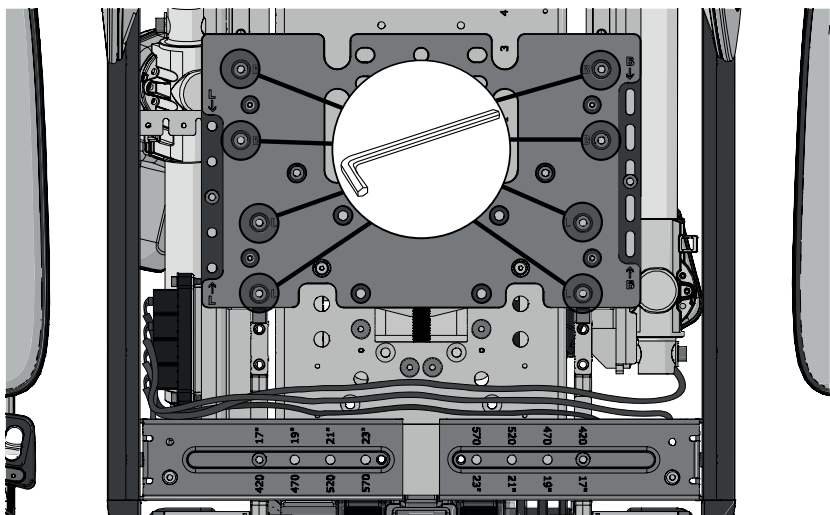

Document No. 278124	Revision D				permobil
Production state SERIES					
Preform Date 2016-07-13	Preform By ROHO	Approved Date 2018-03-05	Approved By basel.nopri	Page 30	

9 Return these 10 bolts to their original location and snug them tight. They will be removed again at a later stage.

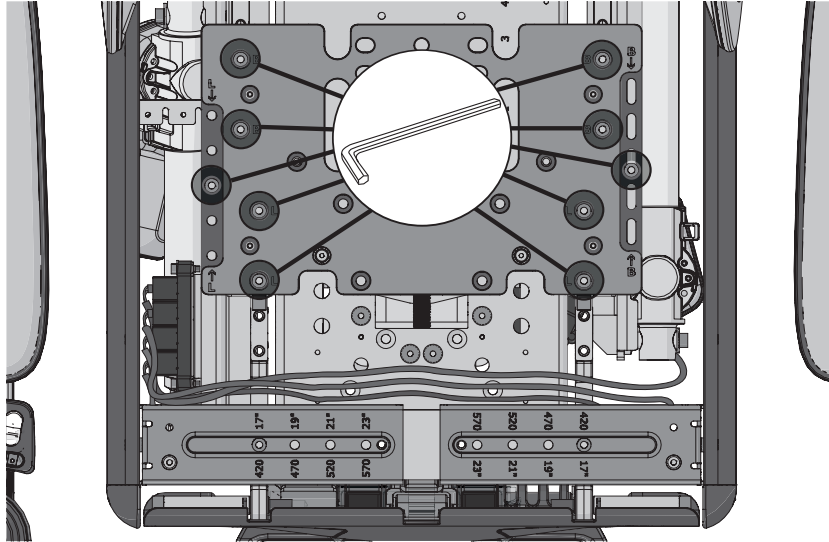

10 Remove the two M6x12 bolts securing the rear seat bar to the top plate.

! The seating system is unbolted from the top plate in these steps. Carefully slide the seating system to and fro to gain access to the bolts required.

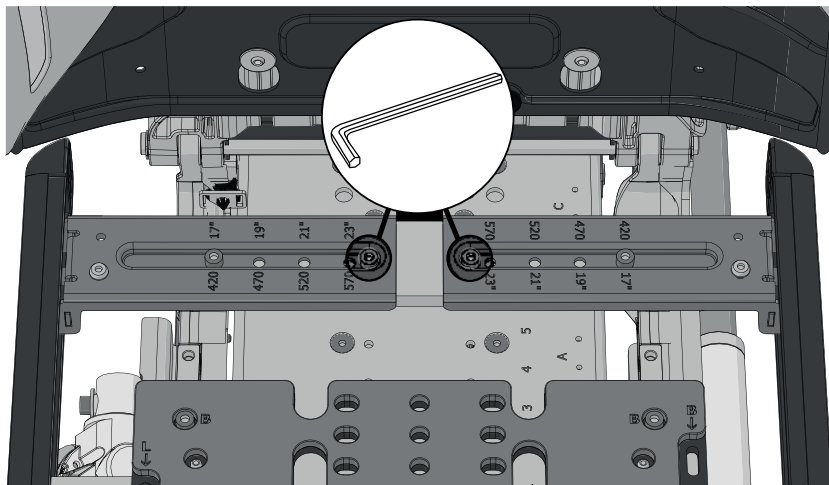

11 Carefully position the seating to gain access to the four bolts securing the actuator's holder. Remove the bolts securing the actuator's holder. Save the bolts.

! The seating system is unbolted from the top plate in these steps. Carefully slide the seating system to and fro to gain access to the bolts required.

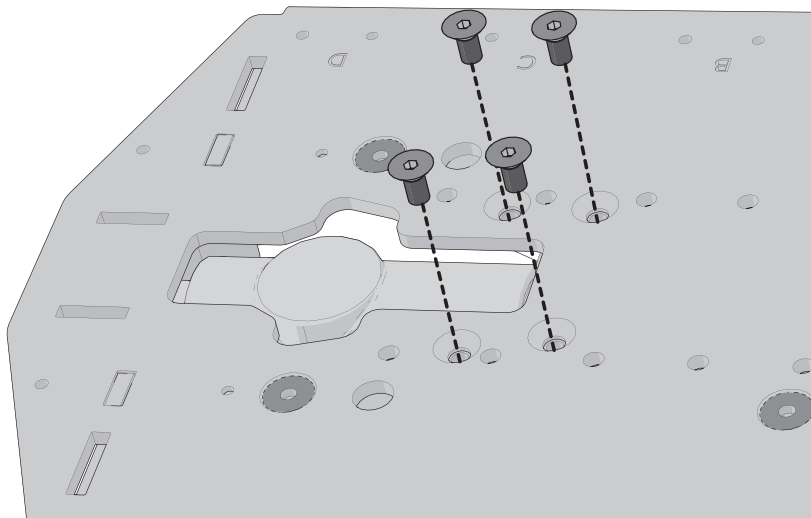

Document No. 278124	Revision D				permobil
Production state SERIES					
Preform Date 2016-07-13	Preform By ROHO	Approved Date 2018-03-05	Approved By basel.nopri	Page 32	

15 Check that the leg rest is fully elevated.

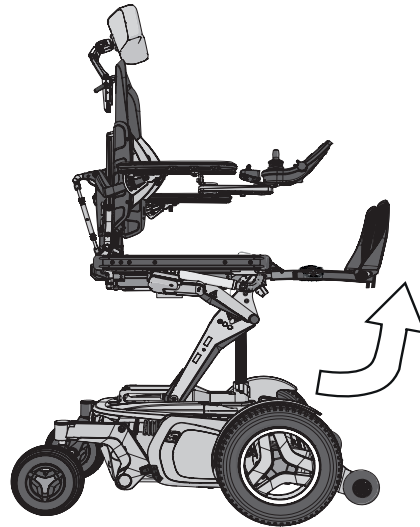

16 Enter seating into the Emergency operation mode.

Read instructions completely before starting!

1. Turn off the wheelchair.
2. Press and hold button 6 and button 8 on the ICS switchbox.
3. While holding these buttons, turn on the wheelchair with Power button on the joystick (or input device). All LED:s on the ICS switchbox will glow green, continue to hold buttons 6 and 8.
4. When all the ICS switchbox LED:s glow red, release buttons 6 and 8 (approximately 30 seconds). The switchbox LED:s will oscillate green to signify you are in Manual operation mode. If the switchbox LED:s do not oscillate green, begin again.



17 Press and hold button 5 to anterior tilt the seating system. The seating system will move very slowly. Monitor closely for binding or possible collision of seating.



Document No. 278124	Revision D				permobil
Production state SERIES					
Preform Date 2016-07-13	Preform By ROHO	Approved Date 2018-03-05	Approved By basel.nopri	Page 33	

18 The goal is to anterior tilt the seating to a position that allows easy access to the underside of the top plate. After reaching this position power down the chair.

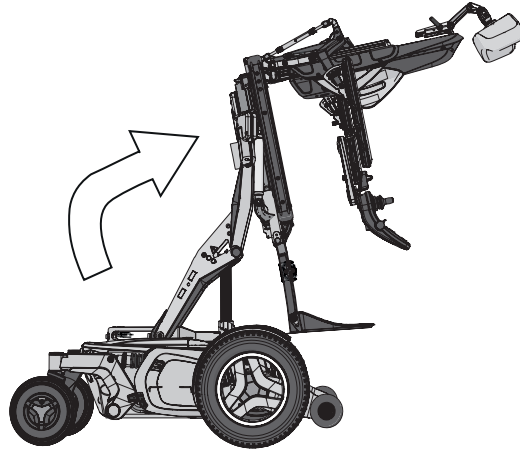

19 Remove the bracket holding the end of the actuator and scrap it. The bracket can look different depending on the revision. See (A), (B) or (C).

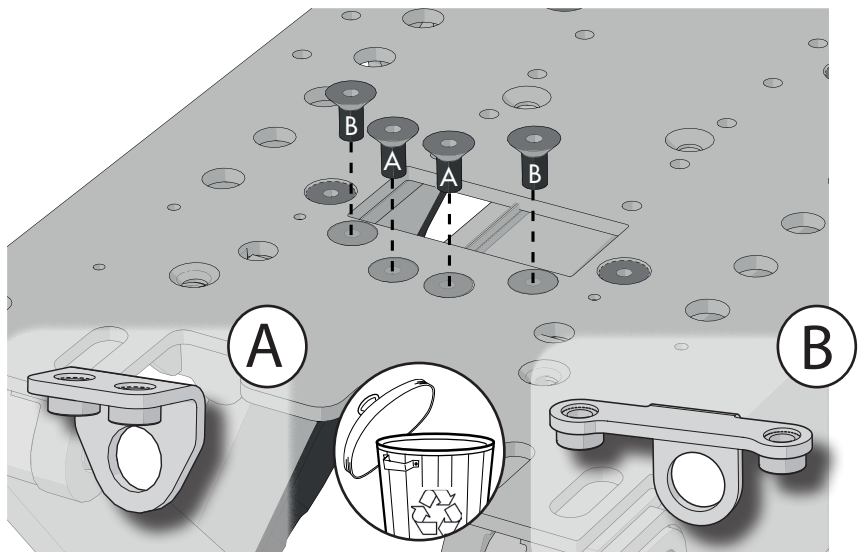

If you have bracket (A) or (B)
Remove the end stop (D) and scrap it.

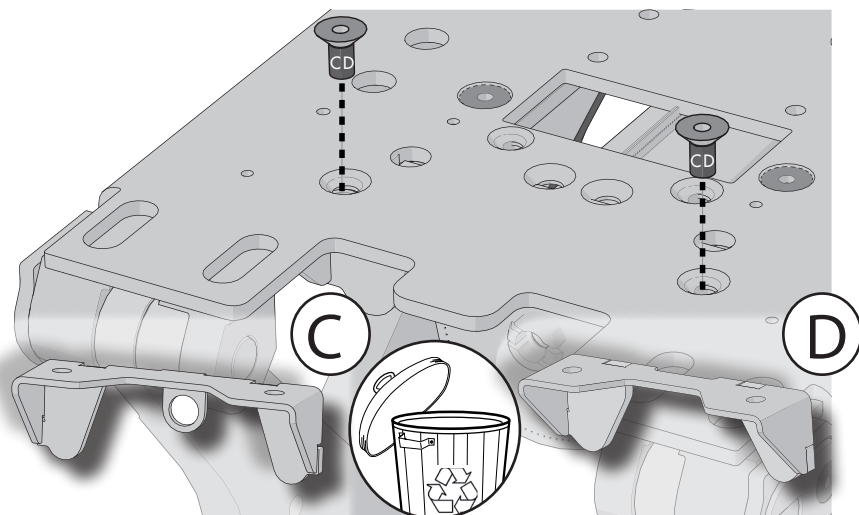

Assembly Instruction

Document No. 278124	Revision D				permobil
Production state SERIES					
Preform Date 2016-07-13	Preform By ROHO	Approved Date 2018-03-05	Approved By basel.nopri	Page 34	

20 Use a strap to secure the elevators position. Attach the strap to the leg rest and the shaft of the lower back of the AP elevator.

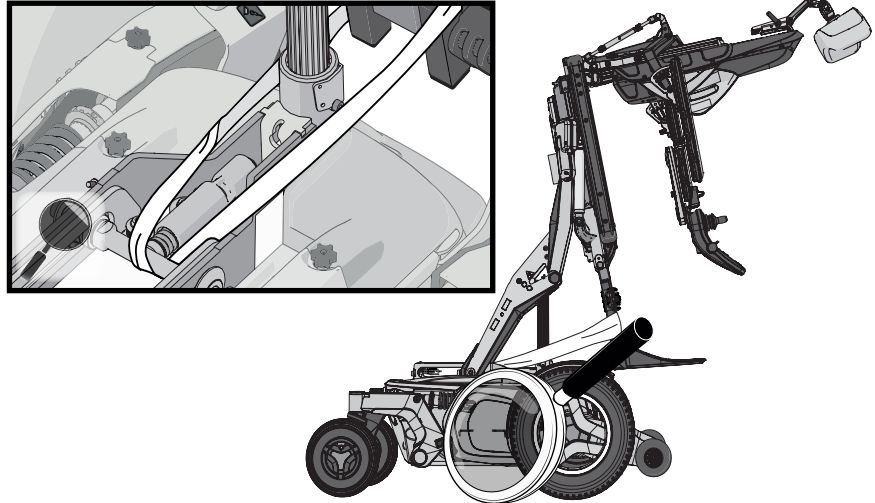

21 Remove the pinch guard from the top plate.

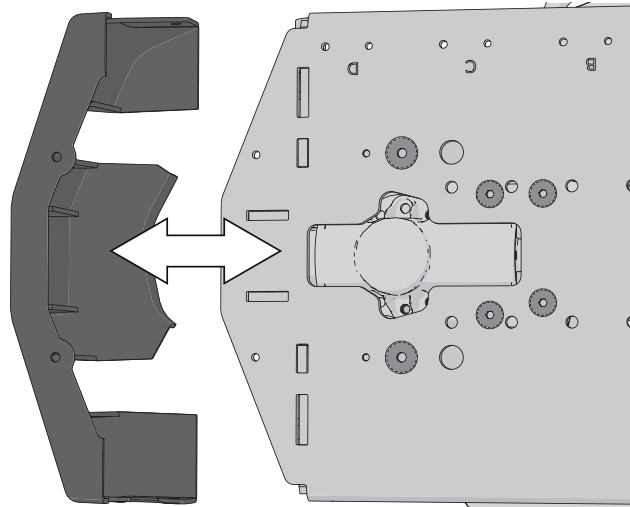

22 Remove the cable clip securing the wiring harness from the actuator. Disconnect the actuator lead from ICS system.

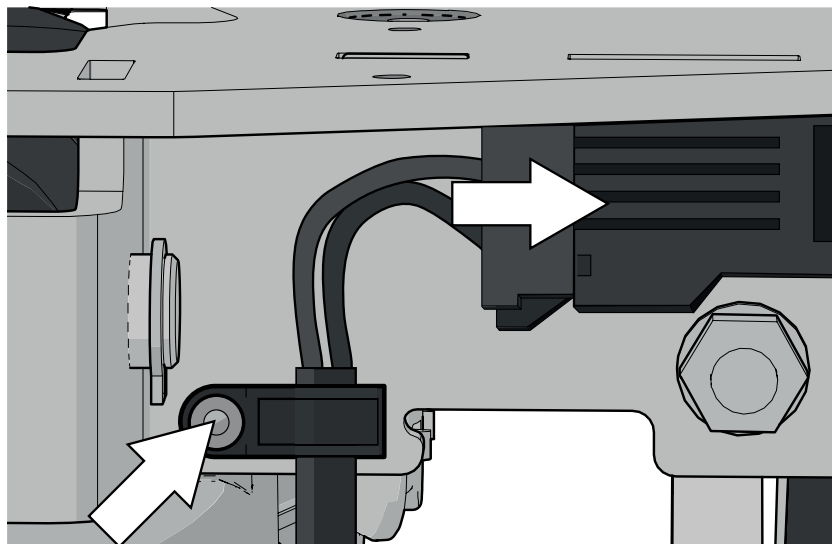

Document No. 278124	Revision D				permobil
Production state SERIES					
Preform Date 2016-07-13	Preform By ROHO	Approved Date 2018-03-05	Approved By basel.nopri	Page 35	

23 Remove the snap ring and pin securing the actuator to the top plate assembly.

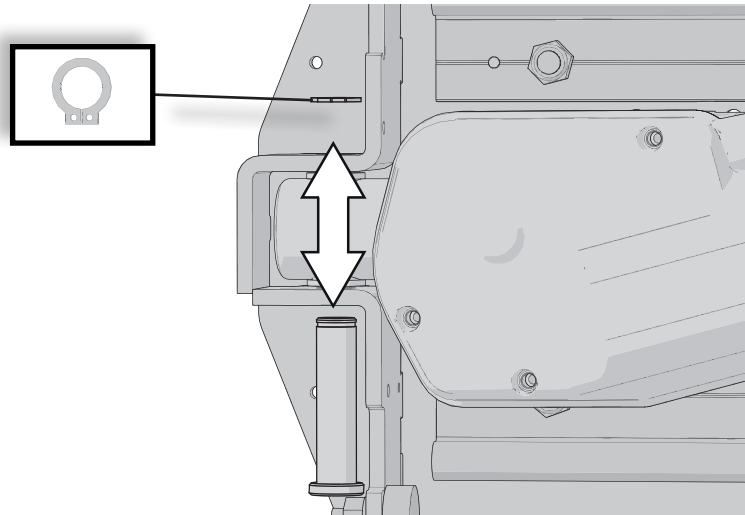

24 Depending on the revision of the carriage there are different actions.
Carriage (A): Remove the nut and scrap it. Remove the M6 and M5 screws and scrap them. Save the locking plate for later installation.

 The textile cover should always be replaced when the actuator is replaced.

Carriage (B): Remove the three M5 screws and scrap them. Save the locking plate for later installation.

 The textile cover should always be replaced when the actuator is replaced.

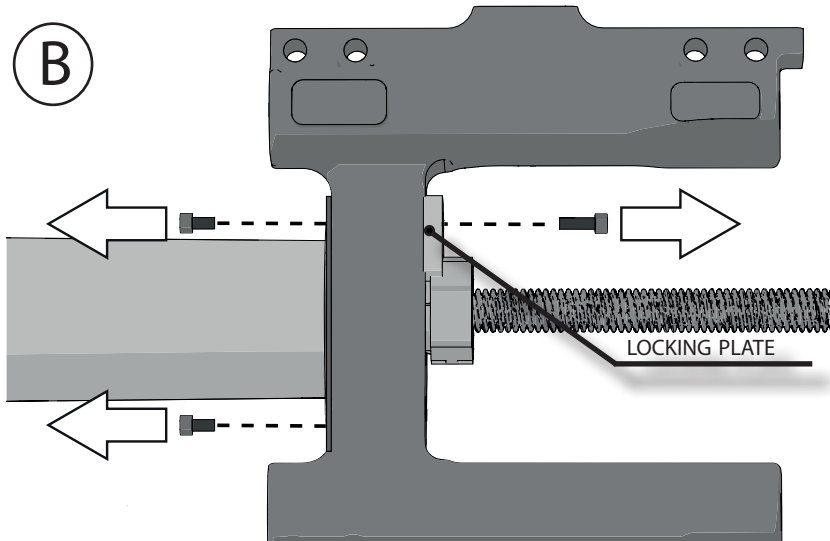
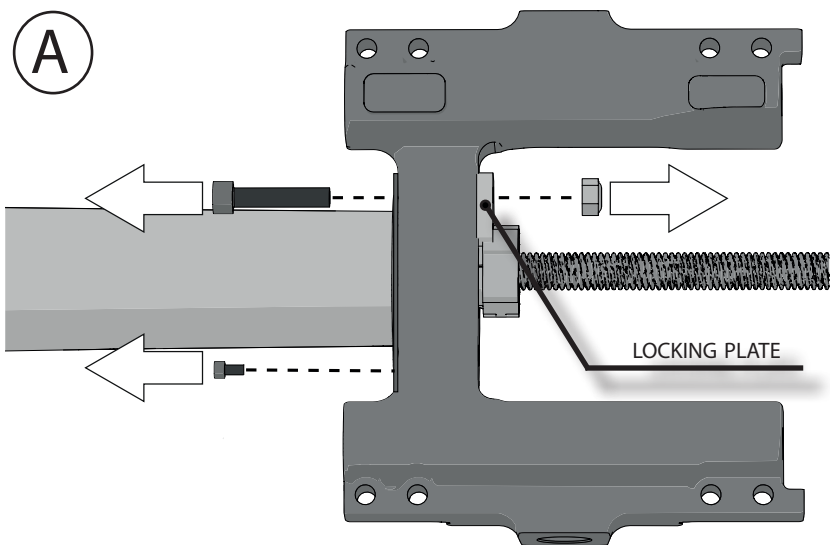

Document No. 278124	Revision D				permobil
Production state SERIES					
Preform Date 2016-07-13	Preform By ROHO	Approved Date 2018-03-05	Approved By basel.nopri	Page 36	

25 Unthread the polymer nut from the carriage.



Do not further move the position of the polymer nut after it is unthreaded from the carriage.

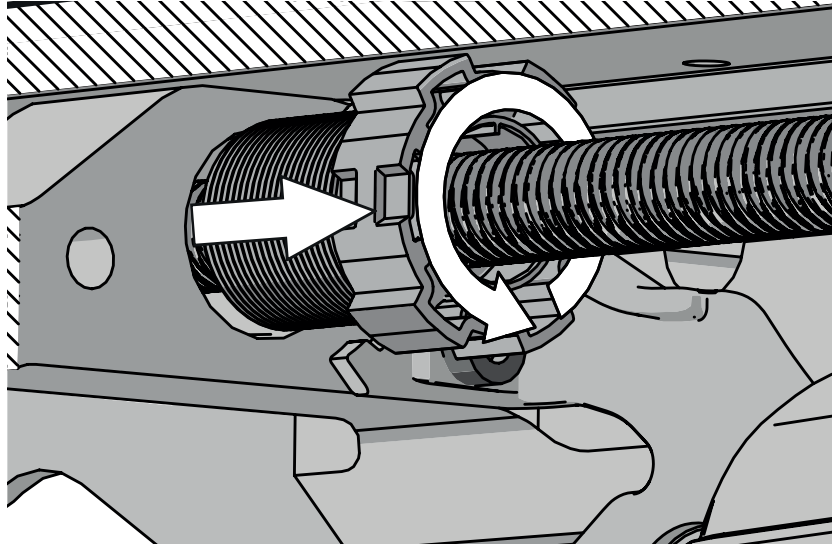

26 Remove the actuator.

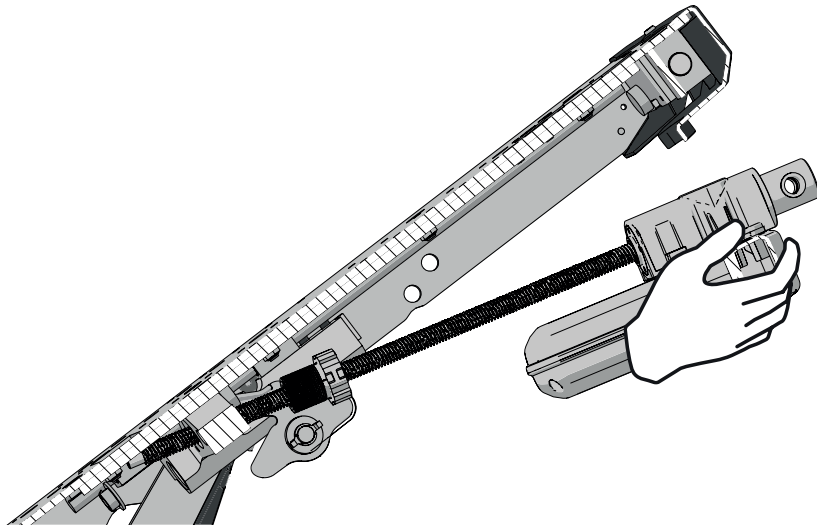

27 Remove the screw and the magnet holder and scrap them.

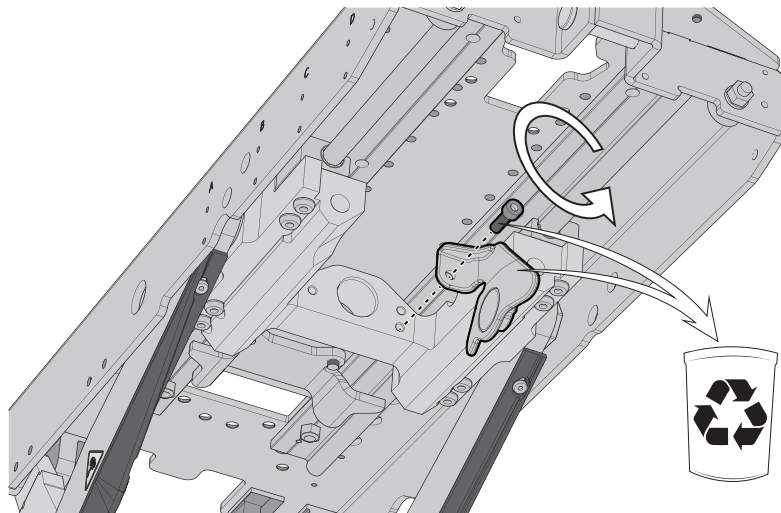

Document No. 278124	Revision D				permobil
Production state SERIES					
Preform Date 2016-07-13	Preform By ROHO	Approved Date 2018-03-05	Approved By basel.nopri	Page 37	

28

Mount the new magnet holder with the M5x16 screw

Tighten the screw with 2,9 Nm.

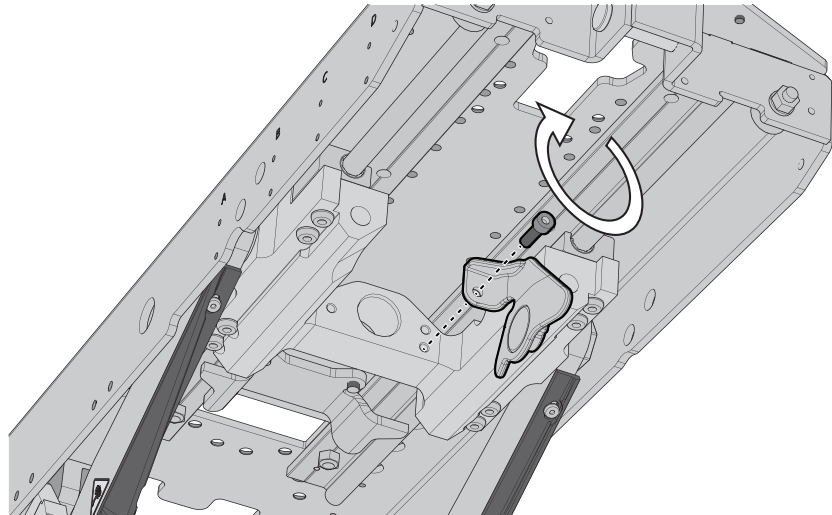
**29**

Position, by eye, the polymer nut on the new actuator in the same position as the nut on the previously removed actuator.

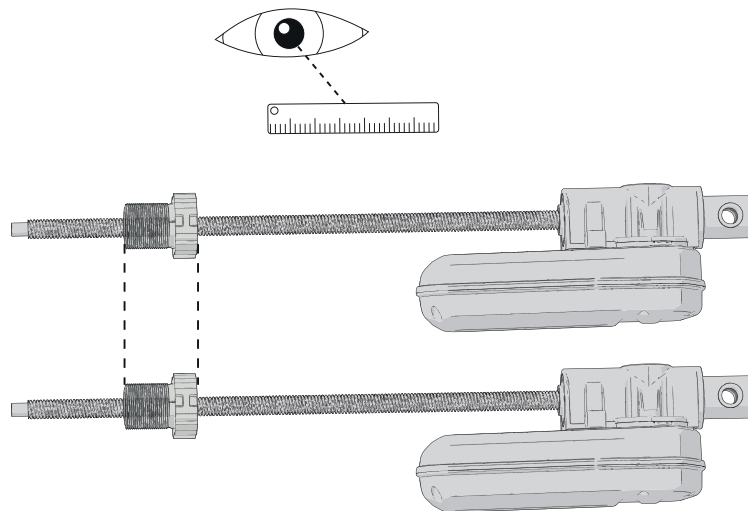
**30**

Insert the new actuator into the carriage. You might need to loosen the strap and tilt back the seat a little in order to fit the new actuator.

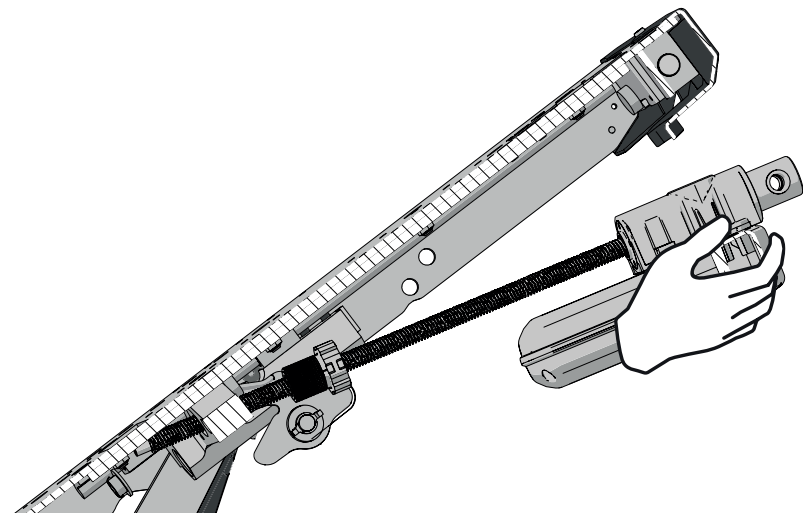

Document No. 278124	Revision D				permobil
Production state SERIES					
Preform Date 2016-07-13	Preform By ROHO	Approved Date 2018-03-05	Approved By basel.nopri	Page 38	

31 Mount the polymer nut in the carriage.



Do not use tools when mounting the polymer nut. Usage of tools can lead to critical damage on the polymer nut.

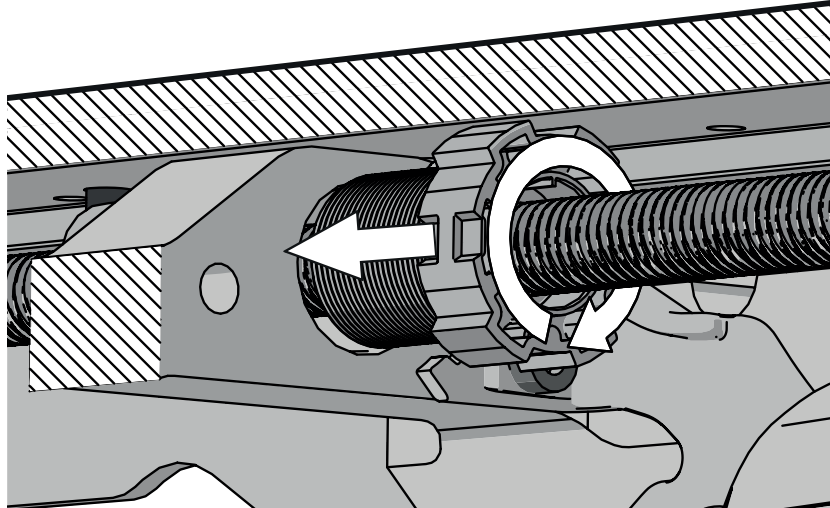

32 There must be a gap of 0.5-1 mm between the polymer nut and the carriage.



This is very important.

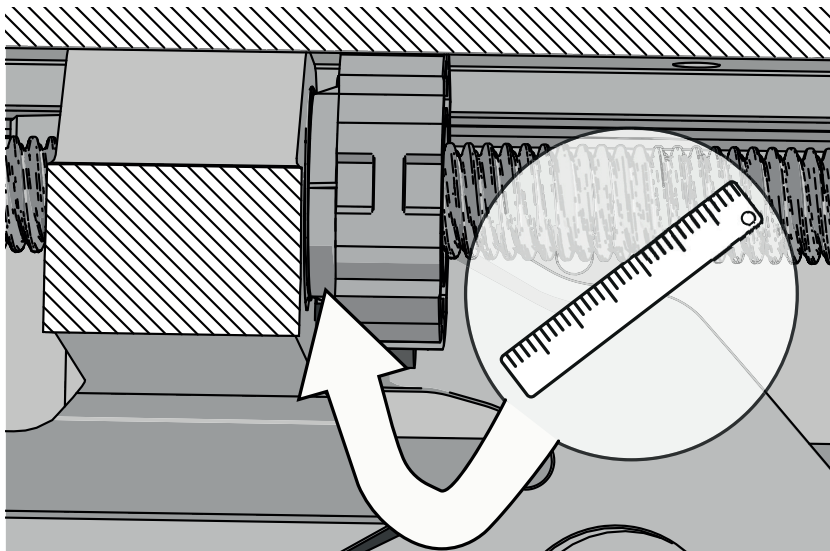

Assembly Instruction

Document No. 278124	Revision D				permobil
Production state SERIES					
Preform Date 2016-07-13	Preform By ROHO	Approved Date 2018-03-05	Approved By basel.nopri	Page 39	

33 Mount the snap ring and pin securing the actuator to the top plate assembly.

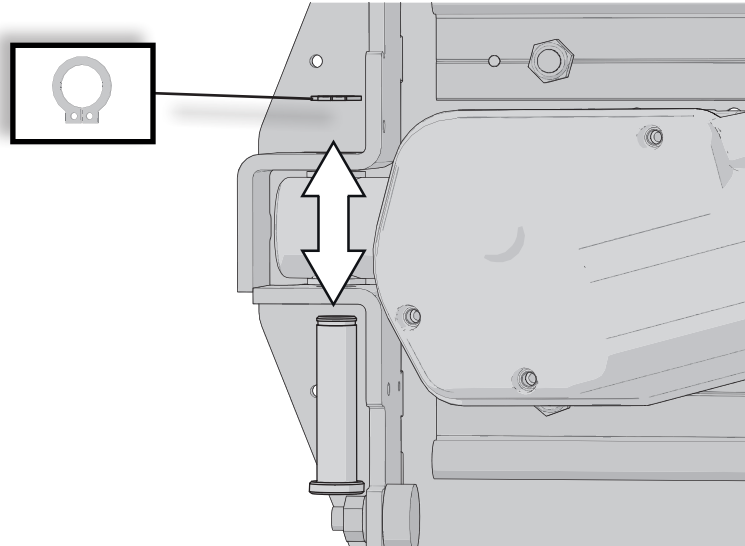

34 Detach the strap from the leg rest and the shaft of the lower back of the AP elevator.

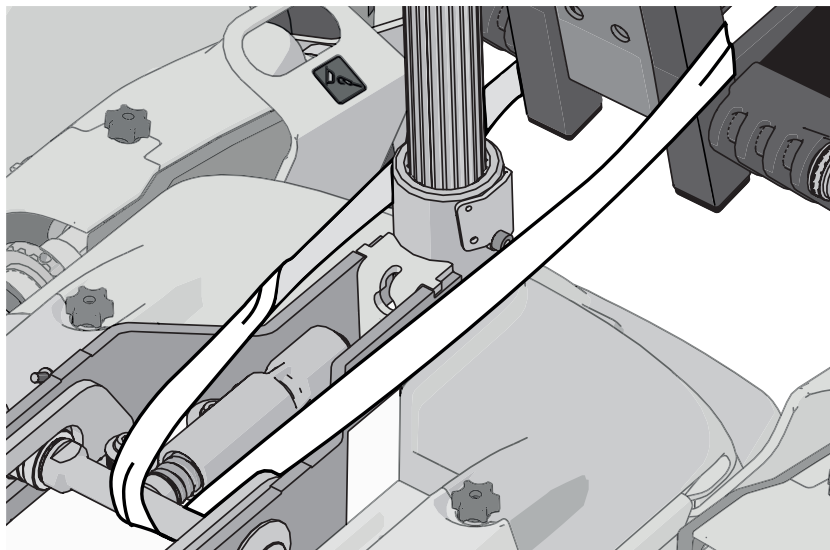

35 This step is only necessary if the textile cover is in separate parts.

Drop the plastic bushing inside the textile cover. Work the bushing into the hole at the other end as shown.

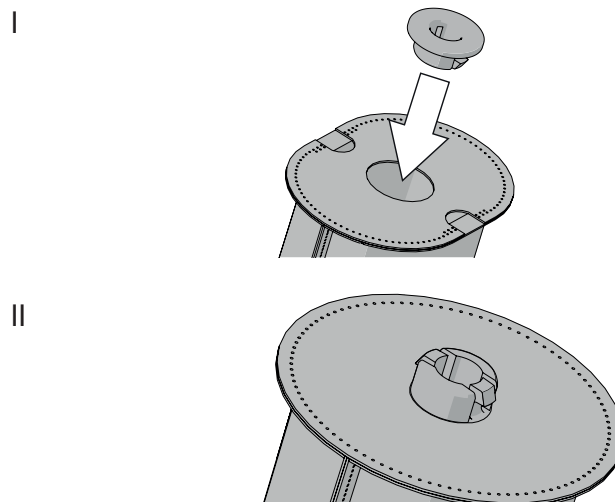

Assembly Instruction

Document No. 278124	Revision D				permobil
Production state SERIES					
Preform Date 2016-07-13	Preform By ROHO	Approved Date 2018-03-05	Approved By basel.nopri	Page 40	

36 This step is only necessary if the textile cover is in separate parts.

Assemble the plate to the textile cover.

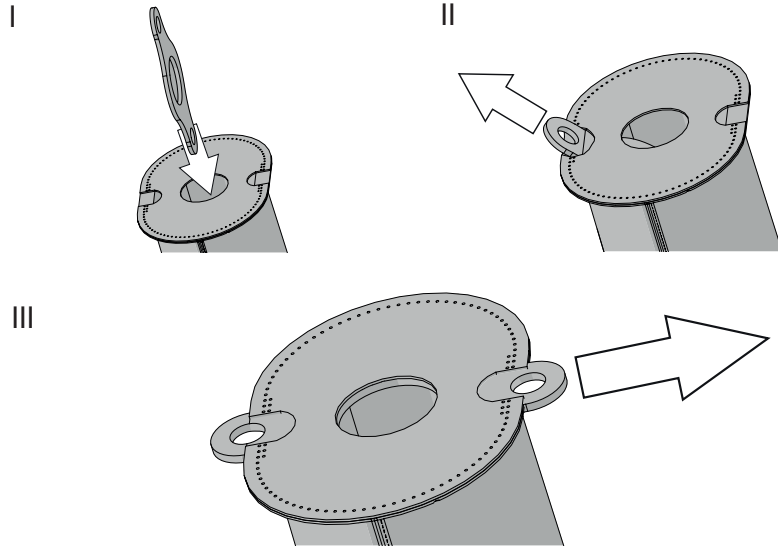

37 Mount the plastic bearing into the bracket.

Apply grease (Molykote PG-75 or equal lubricant compatible with plastic and elastomer) on the inside of the bearing.

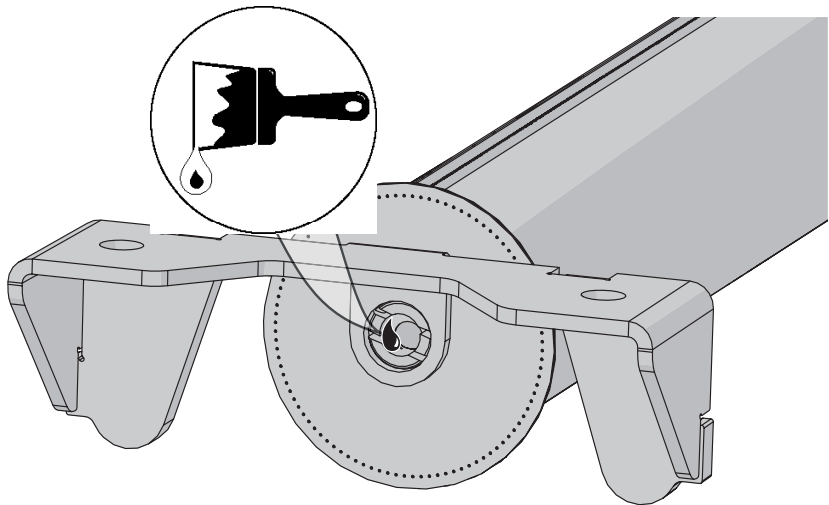

38 Slide the textile tube onto the actuator spindle. Make sure that the seam of the cover is facing the top plate's underside.

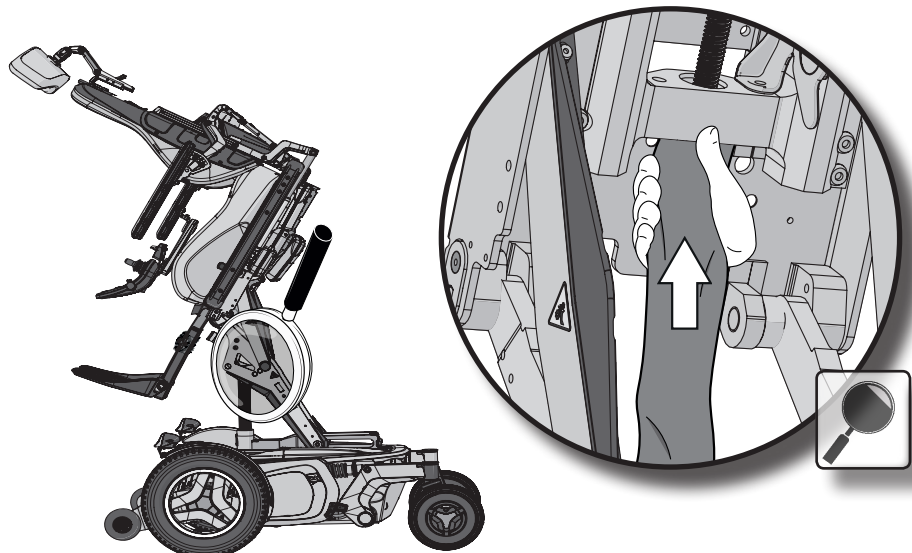

Document No. 278124	Revision D				permobil
Production state SERIES					
Preform Date 2016-07-13	Preform By ROHO	Approved Date 2018-03-05	Approved By basel.nopri	Page 41	

39 Mount one of the new M5x12 screws in the upper hole. Do not tighten the screw.

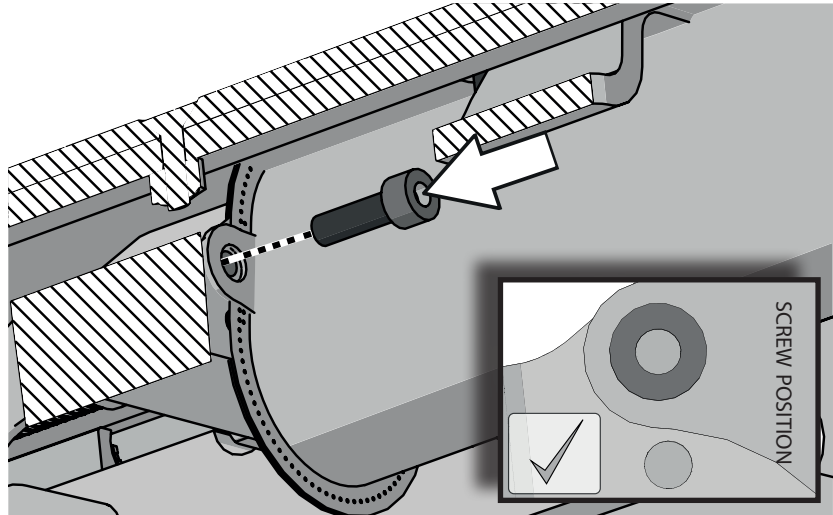

40 Depending on the revision of the carriage there are different actions.

Carriage (A): Mount the new M6x40 screw and washer. Tighten the screw with 9,8 Nm/ 7.2 lb.ft. Mount the new nut, tighten it with 2,9 Nm/2.1 lb.ft. Tighten the screw mounted in step 40. Tighten with 5,7 Nm/4.2 lb.ft.

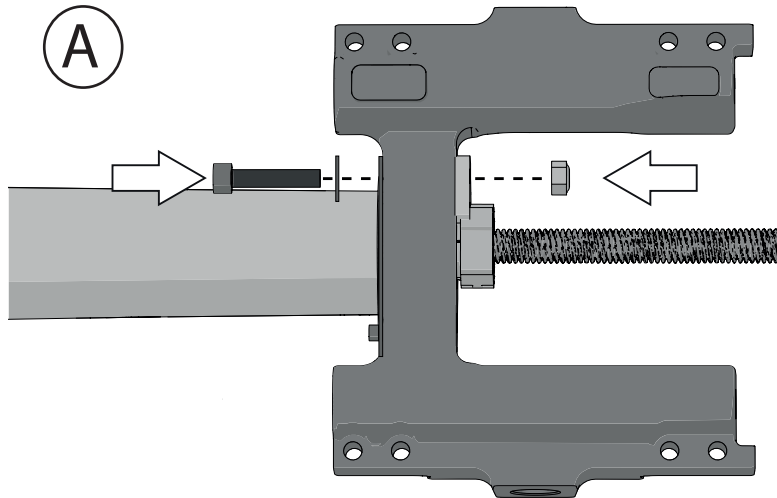

Carriage (B): Mount the M5x16 screw securing the locking plate. Mount the M5x12 screw securing the textile tube. Tighten all three screws, including the screw in step 40, with 5,7 Nm/4.2 lb.ft.

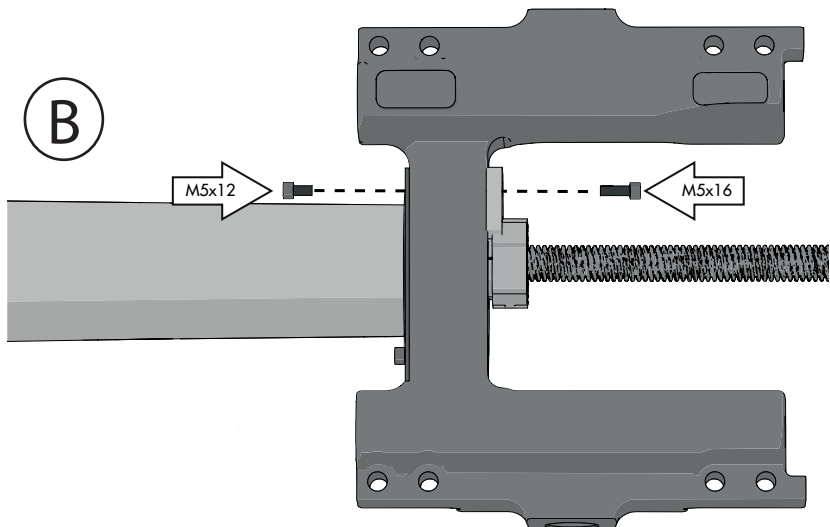

Assembly Instruction

Document No. 278124	Revision D				permobil
Production state SERIES					
Preform Date 2016-07-13	Preform By ROHO	Approved Date 2018-03-05	Approved By basel.nopri	Page 42	

- 41** Connect the actuator lead to the ICS system and power the chair up thru the On/Off button on the input module. After the chair powers up all LED:s flashes red.

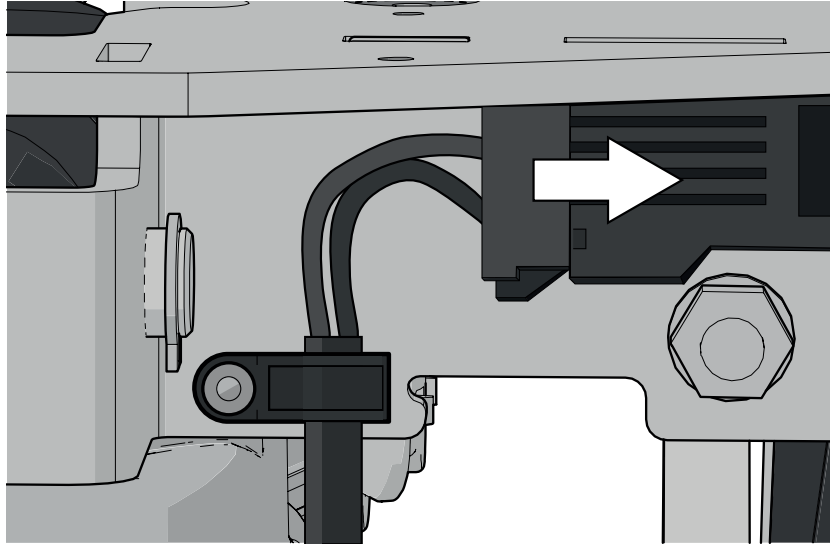

- 42** Turn off the wheelchair and disconnect the actuator lead.

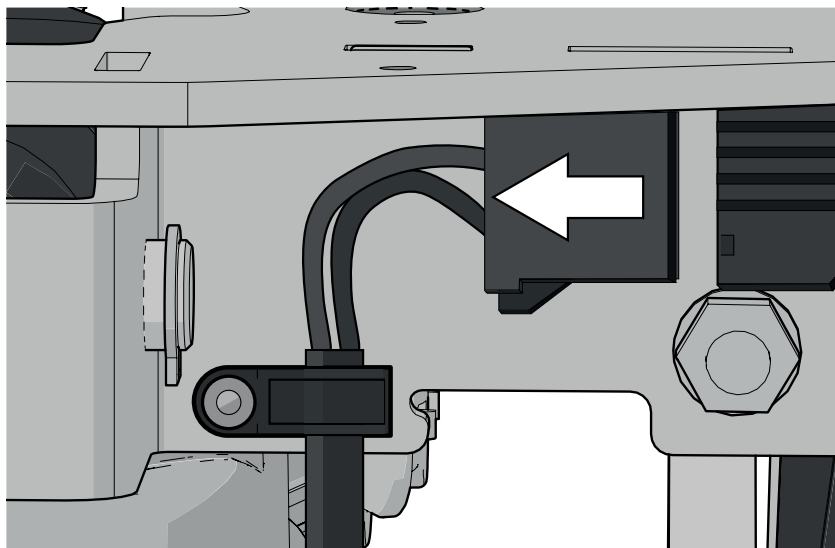

- 43** Power the chair up thru the On/Off button on the input module. After the chair powers up, connect the actuator lead to the ICS system. Install the cable clip securing the wiring harness from the actuator. Tighten the screw for the cable clip with 1,2 Nm/0.89 lb.ft.

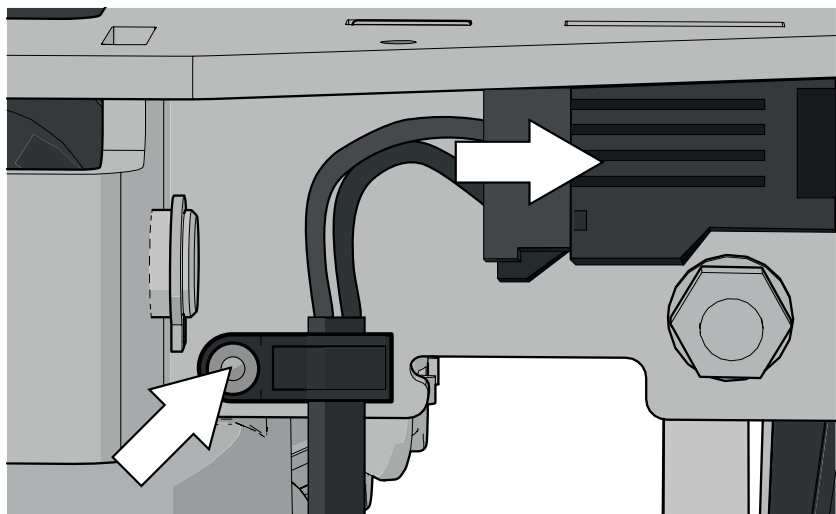

Assembly Instruction

Document No. 278124	Revision D				permobil
Production state SERIES					
Preform Date 2016-07-13	Preform By ROHO	Approved Date 2018-03-05	Approved By basel.nopri	Page 43	

44 LED 1 will now flash red/yellow. The actuator is now in calibration mode.



45 Push and hold button 1 to move the seating from its anterior tilt position to 0° horizontal position.



! Carefully monitor the textile cover as the seating moves. Make certain the cover does not entangle with the rotating spindle.



46 Push the plastic bearing onto the spindle.

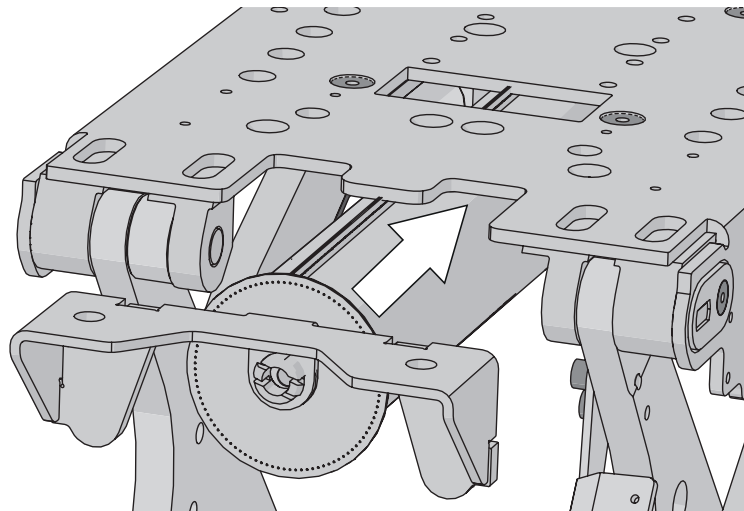

Assembly Instruction

Document No. 278124	Revision D				permobil
Production state SERIES					
Preform Date 2016-07-13	Preform By ROHO	Approved Date 2018-03-05	Approved By basel.nopri	Page 44	

47 Mount the bracket with two screws to the top plate. Tighten with 12,7 Nm/9.4 lb.ft.

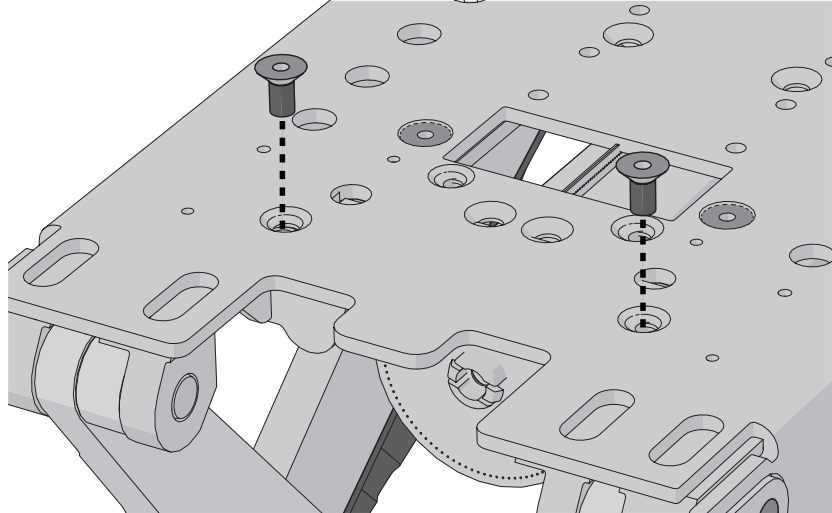

48 Continue to push and hold button 1 until the actuator reaches the end stop and the LED:s flashes red.



49 When the LED:s flash red the system is requesting a restart. The system may require multiple restarts. Power the chair off and back on again. The switchbox will return to normal operation.



Document No. 278124	Revision D				permobil
Production state SERIES					
Preform Date 2016-07-13	Preform By ROHO	Approved Date 2018-03-05	Approved By basel.nopri	Page 45	

50 Return the seating to 0°/horizontal position and elevate the seating for access to the underside of the AP elevator's top plate.



51 Mount back the pinch guard.

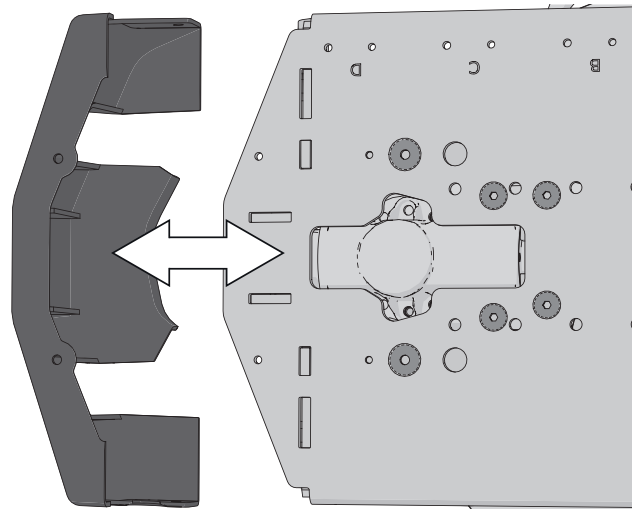

52 Make sure all of the marked bolts are removed so the plastic cover and plate can be moved back.



The seating system is unbolted from the top plate in these steps. Carefully slide the seating system to and fro to gain access to the bolts required.

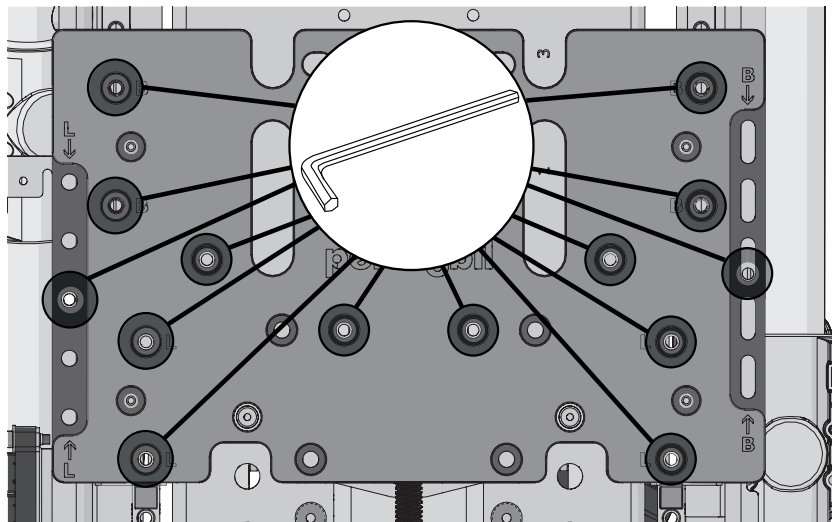

Document No. 278124	Revision D				permobil
Production state SERIES					
Preform Date 2016-07-13	Preform By ROHO	Approved Date 2018-03-05	Approved By basel.nopri	Page 46	

53 Remove the two M6x12 bolts securing the rear seat bar to the top plate. Move the seating system so you can access the screw holes in step 55.

! The seating system is unbolted from the top plate in these steps. Carefully slide the seating system to and fro to gain access to the bolts required.

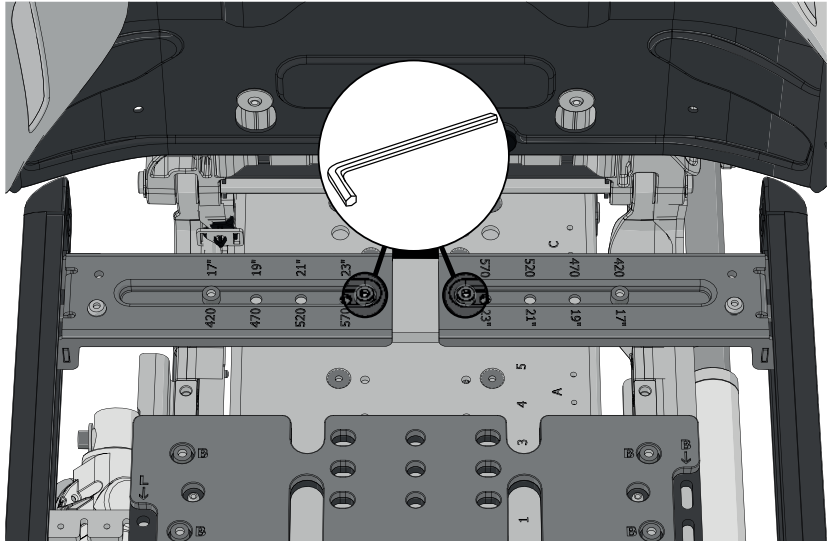

54 Return the actuator's holder.

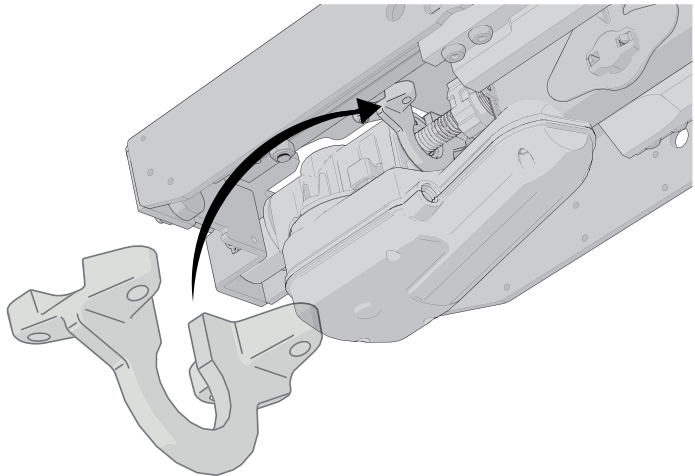

55 Reattach the holder with the four screws. Tighten with 7,4 Nm/5.5 lb.ft.

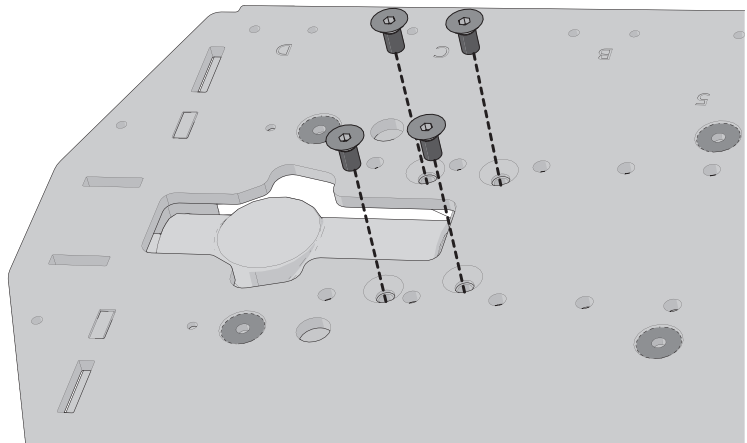

Document No. 278124	Revision D				permobil
Production state SERIES					
Preform Date 2016-07-13	Preform By ROHO	Approved Date 2018-03-05	Approved By basel.nopri	Page 47	

56 Adjust and reposition the seating to its original depth and center of gravity setting.

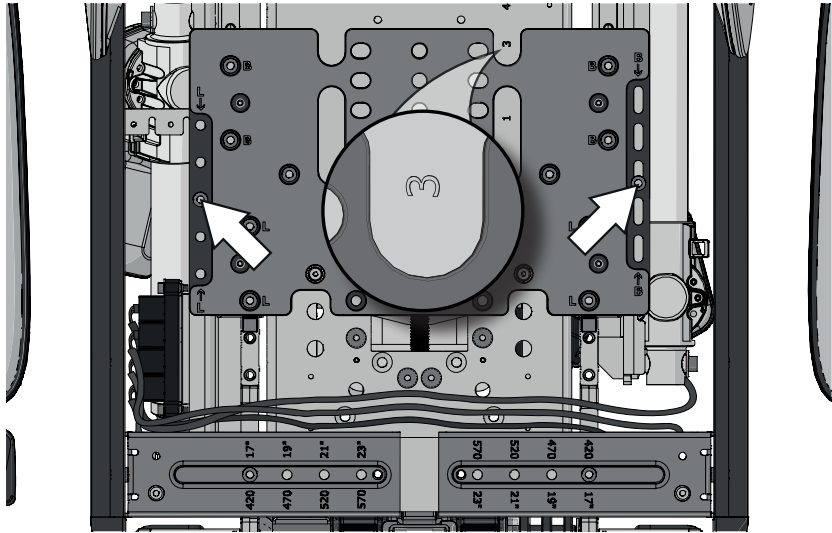

57 Reattach the bolts securing the plastic cover and plate. Tighten with 9,8 Nm/7,2 lb.ft.

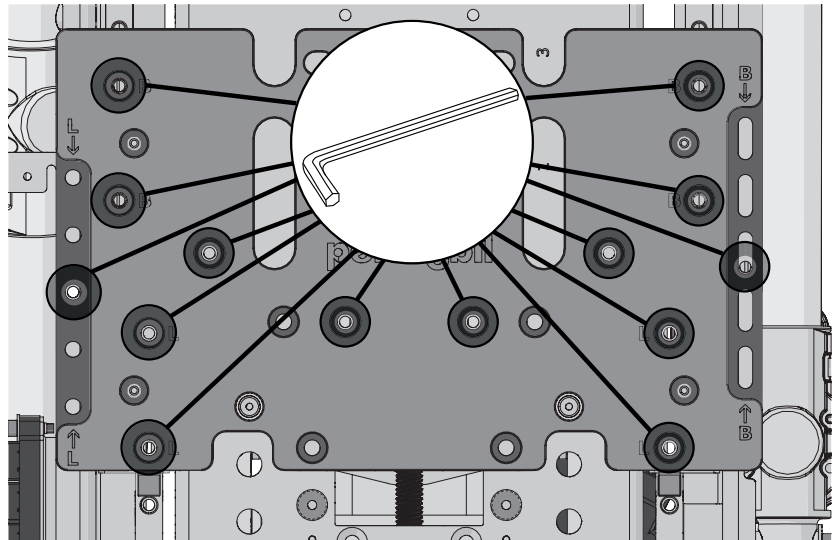

58 Reattach the two M6x12 bolts securing the rear seat bar to the top plate. Tighten with 9,8 Nm/7,2 lb.ft.

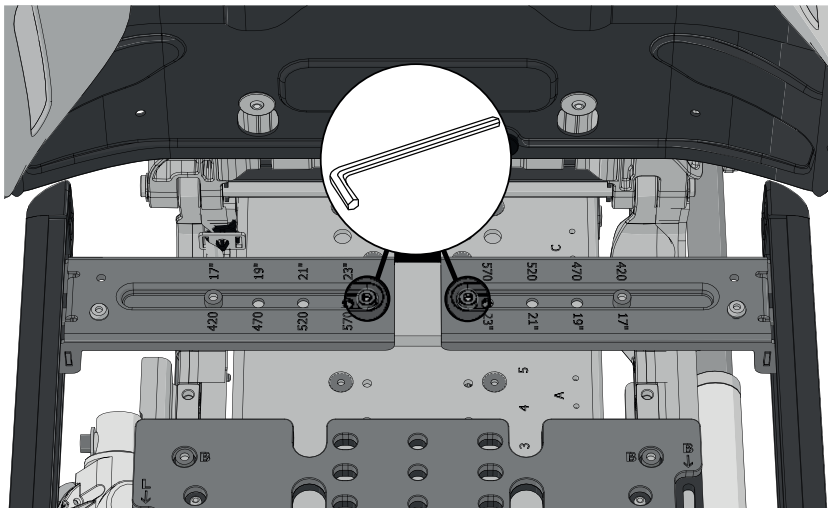

Document No. 278124	Revision D				permobil
Production state SERIES					
Preform Date 2016-07-13	Preform By ROHO	Approved Date 2018-03-05	Approved By basel.nopri	Page 48	

59 Reattach the cable clips with cables in them. Tighten with 1,2 Nm/11 in-lbs.

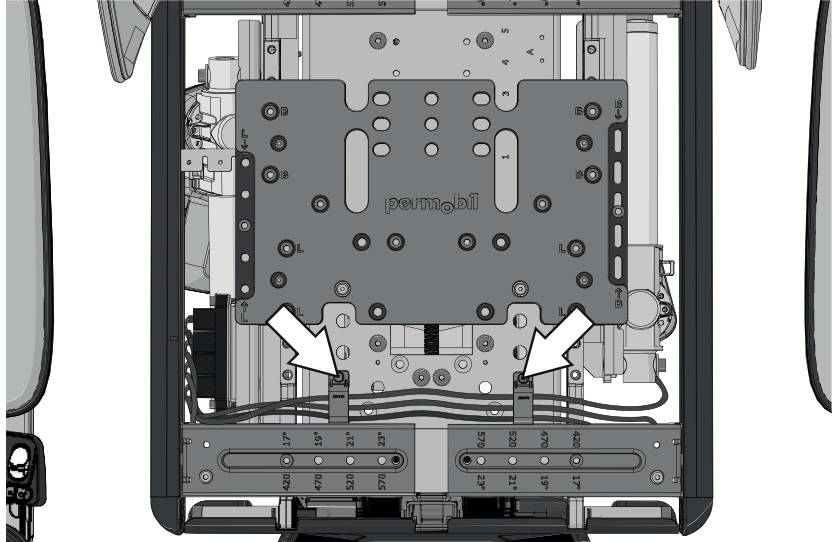

60 Reattach the seat plates, which are held in place by four screws. Tighten with 9,8 Nm/7,2 lb.ft. Reattach the seat cushions. It is attached by means of velcro on the rear of the cushion.

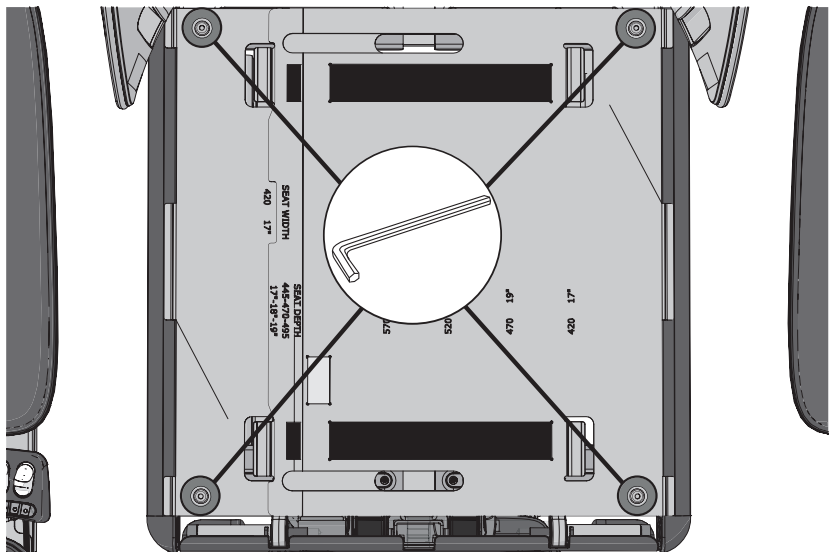

61 Carefully test the system for proper operation of the seat functions. Pay particular attention to the operation of tilt and the seat lift in both directions of travel. Make certain the textile cover cannot become entangled in the rotating spindle.

